

Student Edition



# Physical Science

Can I Believe  
My Eyes?

*Second Edition*



# CAN I BELIEVE MY EYES?

**Light Waves, Their Role in Sight, and Interaction with Matter**

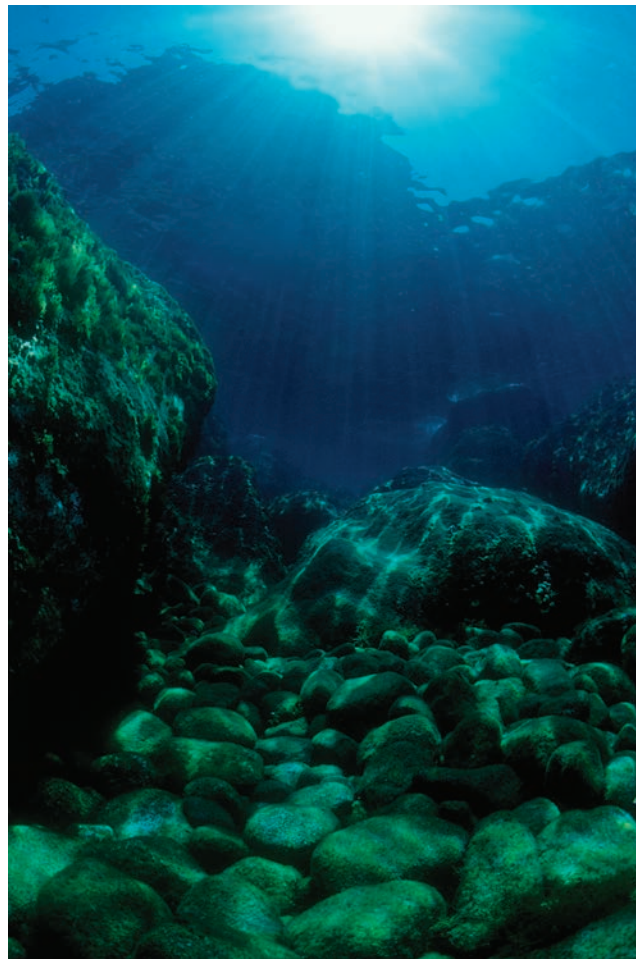

## **IQWST LEADERSHIP AND DEVELOPMENT TEAM**

Joseph S. Krajcik, Ph.D., Michigan State University  
Brian J. Reiser, Ph.D., Northwestern University  
LeeAnn M. Sutherland, Ph.D., University of Michigan  
David Fortus, Ph.D., Weizmann Institute of Science

### ***Unit Leaders***

Strand Leader: David Fortus, Ph.D., Weizmann Institute of Science  
David Grueber, Ph.D., Wayne State University  
Jeffrey Nordine, Ph.D., Trinity University  
Jeffrey Rozelle, Ph.D., Syracuse University  
Christina V. Schwarz, Ph.D., Michigan State University  
Dana Vedder Weiss, Weizmann Institute of Science  
Ayelet Weizman, Ph.D., Weizmann Institute of Science

### ***Unit Contributor***

LeeAnn M. Sutherland, Ph.D., University of Michigan

### ***Unit Pilot Teachers***

Dan Keith, Williamston, MI  
Kalonda Colson McDonald, Bates Academy, Detroit Public Schools, MI  
Christy Wonderly, Martin Middle School, MI

### ***Unit Reviewers***

Vincent Lunetta, Ph.D., Penn State University  
Sofia Kesidou, Ph.D., Project 2061, American Association for the Advancement of Science

*Investigating and Questioning  
Our World through Science  
and Technology  
(IQWST)*

# CAN I BELIEVE MY EYES?

**Light Waves, Their Role in Sight, and Interaction with Matter**



*Student Edition*  
*Physical Science 1 (PS1)*  
*PS1 Eyes SE 2.0.2*  
*ISBN-13: 978-1-937846-47-3*

Physical Science 1 (PS1)  
Can I Believe My Eyes?  
Light Waves, Their Role in Sight, and Interaction with Matter

ISBN-13: 978-1-937846-47-3

Copyright © 2013 by SASC LLC. All rights reserved. No part of this book may be reproduced, by any means, without permission from the publisher. Requests for permission or information should be addressed to SASC LLC, 50 Washington Street, 12th floor, Norwalk, CT 06854

## About the Publisher

Sangari Active Science Corporation is a mission-driven company that is passionate about STEM education. We make it easy for teachers to teach with quality, investigation-centered science curriculum, tools, and technology. For more information about what we do, please visit our website at <http://www.sangariglobaled.com>.



IQWST (Investigating and Questioning Our World through Science and Technology) was developed with funding from the National Science Foundation grants 0101780 and 0439352 awarded to the University of Michigan, and 0439493 awarded to Northwestern University. The ideas expressed herein are those of members of the development team and not necessarily those of NSF.

## PS1 CONTENTS

<i>Scientific Principles</i>	vi
<i>Driving Question Notes</i>	viii
Lesson 1 – Anchoring Activity and Driving Question Board	1
Lesson 2 – What Do We Need to See an Object?	7
Lesson 3 – Constructing Models of How People See	15
Lesson 4 – The Eye as a Light Sensor	25
Lesson 5 – How Are Shadows Created?	35
Lesson 6 – Scattering and Reflection of Light	51
Lesson 7 – Transmission of Light	73
Lesson 8 – Absorption of Light	91
Lesson 9 – What Is the Opposite of White Light?	105
Lesson 10 – How Do Objects Change the Color of Light?	115
Lesson 11 – Back to the Anchoring Activity	127
Lesson 12 – Infrared Light and the Wave Model	135
Lesson 13 – Ultraviolet Light and Nonvisible Light Imagery	145







## **DRIVING QUESTION NOTES**

---

Use these sheets to organize and record ideas that will help you answer the Driving Question or your own original questions.

## DRIVING QUESTION NOTES

---

# DRIVING QUESTION NOTES

---

## DRIVING QUESTION NOTES

---

# DRIVING QUESTION NOTES

---

## DRIVING QUESTION NOTES

---

## *ART*

Every effort has been made to secure permission and provide appropriate credit for the photographic materials in this program. The publisher will correct any omission called to our attention in subsequent editions. We acknowledge the following people and institutions for the images in this book.

### *Lesson 1*

Optical Illusion 2 – *Wikipedia, The Free Encyclopedia*

### *Lesson 3*

Solar Sail – National Aeronautics and Space Administration, U.S. Government

### *Lesson 6*

Hardwood Pores – *Wikipedia, The Free Encyclopedia*

### *Lesson 13*

Satellite Photograph of Earth – Courtesy National Oceanic and Atmospheric Administration, U.S. Department of Commerce

## LESSON 1

# Anchoring Activity and Driving Question Board

### ACTIVITY 1.1 – ANCHORING ACTIVITY – STRANGE IMAGES

#### What Will We Do?

We will observe two strange images. By the end of the unit, we will be able to explain how these images work.

#### Procedure

1. Look at the first image your teacher projects. What do you see? Record your observations in the data table.
2. Your teacher will project a second image. Which square appears darker to you, square A or square B? Record what you see in the data table.
3. Your teacher will make some changes to the second image. Which square appears darker now, square A or square B? Record your observations.

#### Data

Image	What I See
First Image	
Second Image	
Second Image with Additions	

#### Making Sense

1. What did you notice about the circles in the first image?



2. Do you think what happened was real? How do you know?
  
3. Why do you think that square A and square B looked different the first time you looked at them than they did the second time you looked at them?
  
4. Asking and exploring the answers to questions is important to science. Does this activity make you think of any questions about light or about things you see? List your questions in the following space.



## Reading 1.1 – Look at This!

### Getting Ready

The picture shows two bent rectangles. Which bent rectangle is longer?

Now use a ruler to measure the size of the two bent rectangles. Were you correct? To most people, B looks longer than A. When you measured, you might have learned that your guess was wrong. In this reading, you will learn how your brain can get confused by what your eyes see. You will be able to compare the figures in this reading to what you saw in class.

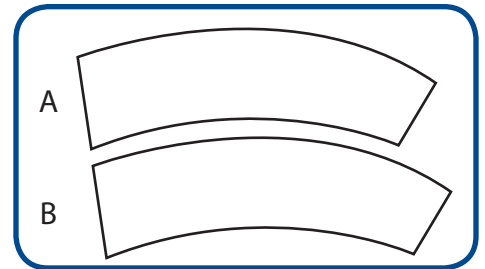

To compare means to think about what is alike and what is different. As you read, think about what is similar and different about the light box and the pictures in this reading.

### What Are Optical Illusions?

Look at these pictures.

Stare at the small dot in the center of the circles. Now move the picture closer to you while you keep looking at the dot. What happens?

Tricks like these are called *optical illusions*. *Optical* is a word related to your sense of sight. Many other words start with the prefix *opt-*. An optometrist is an eye doctor. If you need glasses, an optician may have helped you choose your glasses.

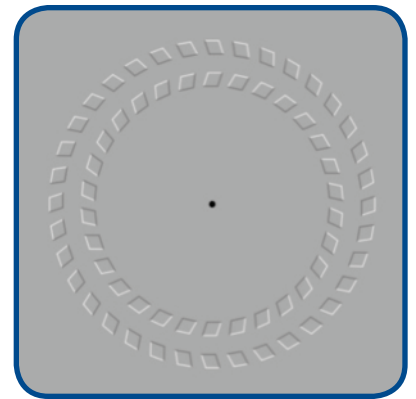

You may have seen magicians who perform illusions. Magicians do not really make things disappear. But they do know how to fool your brain so you think things disappear. Optical illusions can be fun because they fool you. Optical illusions are a kind of trick. Your eyes play an important role in seeing. But your eyes and your brain work together. Your brain is the organ that makes sense of what you see. In the picture in the Getting Reading section, your eyes see two identical bent rectangles. Your eyes see the right thing, but your brain interprets it wrong. When your brain gets it wrong, this is called an illusion. Optical illusions and magician's tricks are not real. Your brain is just fooled.

### Another Optical Illusion

Look at these small dark squares. If you look closely for a few seconds, you will see light gray circles in between the squares. Are the gray circles really there, or do they just seem to be there?

This is another example of an illusion. Your brain is being fooled again.

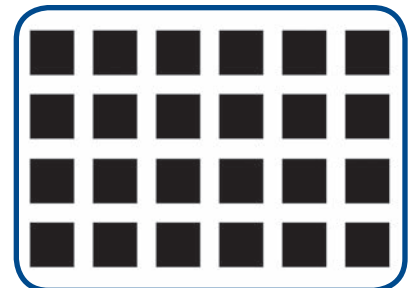

### *Can You Figure This Out?*

Here is one more interesting image. Look at the lines separating the rows of black and white squares.

Do you think what you are seeing is an illusion? Are the lines actually parallel and your brain is being fooled, or are the lines really at angles?

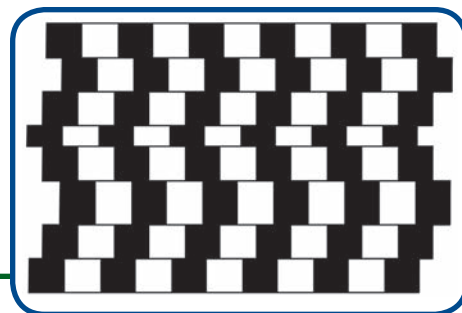

### *Were the Images in Class Optical Illusions?*

In class, you saw strange images. The first looked like a bunch of spinning circles. The second image looked like a checkerboard with a square marked A being clearly darker than another square marked B. Finally, your teacher added black rectangles to the second image and it became apparent that squares A and B had actually identical darkness. These images succeeded in fooling your brain. They were illusions. You observed a real phenomenon. What you saw depended on changes in the light. A phenomenon is an event that happens in the real world and that occurs over and over again.

Sometimes you can observe things that appear very strange but are actually real. For example, have you ever seen the moon disappear in the middle of the night even though it is above the horizon and there are no clouds in the sky? Hold the tips of your thumb and index finger next to each other so that they are just about touching. Hold them up so that they are next to your eye and look between them at a bright white background. You should just barely feel your thumb touching your finger. You should see one or more small black lines between your fingers. From where did these lines come? This is a real thing you are seeing, not an illusion. Your brain is not getting anything wrong. This goal in this unit is to figure out what happens to make people see things, whether they are real or illusions.

Investigating phenomena will help you learn how light affects what you see. In science class, you will observe different phenomena almost every day. By the end of the unit, you may be able to explain how you could see the two images from class.

### *Observing the Two Illusions in Class*

An important part of science is making observations. An observation is the act of paying careful attention to events that happen in the world. This is what you did in class. You paid close attention to what you could see when you looked at the two images. Making good observations, plus learning the science that goes with them, will help you to explain things that happen around you.

### *What Questions Do You Have?*

List questions you have about light, seeing, or about the two images from class now that you have finished reading.



### *Why Is Light Important?*

You already know that light helps you see. But did you know that if you understand the behavior of light, you can also understand how cell phones and microwave ovens work? The scientific ideas that explain the behavior of light also explain how computers, televisions, satellites, GPS, and many other systems work. In fact, many scientific discoveries from the last 100 years are based on the same principles that explain the behavior of light. You will not study all of these in class, but you will learn about many of them. You might also decide to investigate other uses of light on your own. You may be surprised to learn that light plays an important role in just about everything around you.

## ACTIVITY 1.2 – DRIVING QUESTION BOARD





3. As your teacher names objects in the room, record them in the data table. Then put a check mark (✓) in the appropriate column. You will not be able to see everything your teacher names. It is important that you keep your body and your eyes in the same position as you collect data.

<b>Objects around the Classroom</b>		
<b>Object</b>	<b>I CAN See</b>	<b>I CANNOT See</b>

### **Making Sense**

4. What factors affect whether you can see an object or not?

## ACTIVITY 2.2 – DETERMINING THE CONDITIONS FOR SIGHT – THE LIGHT BOX

### What Will We Do?

We will gather evidence about what needs to happen in order for people to see an object.

### Procedure 1

Follow your teacher’s directions. Record your observations from each step before you move on to the next step.

- A. Look into the light box. Be sure the lid and the flap remain closed. In the data table, draw what you see.
- B. Keep the light box lid closed. Open the side flap. Look into the light box. In the table, draw what you see.

### Data

Light Box Activity Results

	First: Lid Closed and Flap Closed	Second: Lid Closed and Flap Open
Observation		

### Making Sense

1. Compare your observations.
  
2. Why were your observations different?



## Procedure 2

Your teacher will add a divider to your light box. Keep the box lid closed and the side flap open. Draw what you see in the following space. Include as much detail as you can.



## Making Sense

1. Compare your drawing with other students' drawings. How can you explain the differences?
2. List the conditions that need to be met in order for people to see an object. This list should be agreed upon by the whole class.
3. Imagine that you look out the door of your science class just as a friend walks by and waves to you. Explain how you can see your friend in the hall. Be sure to use all of the conditions you previously listed in your explanation.



## Reading 2.2 – Picture This!

### Getting Ready

Look closely at the picture. Hold the paper close to your face. Now, set your book down and look at the picture from across the room.

Why do the small pictures you can see up close look like one big picture from across the room?



In this reading, you will learn how a similar idea makes the pictures that you see on TV.

### How Do People See Objects around Them?

In class, you learned about things that affect what people see. You learned that the girl in the image your teacher projected can see the tree because light travels from the sun, bounces off the tree, and enters her eye.



Image 1



Image 2

In the second image your teacher projected, something different happens. Light from the sun bounces off the car, but this time the girl cannot see the car. Some of the light travels toward her, but it cannot enter her eye, because the wall blocks its path. If the light bouncing off the car does not enter her eye, the girl cannot see the car.

Do you think the girl in Image 1 can see the sun? Why? (Be sure to write about the path the light might take.)



Do you think the girl in Image 2 can see the sun? Explain your ideas. (Be sure to write about the path the light might take.)



In Lesson 2, you looked for objects around the room. You learned that you could only see some of the objects from your seat. You could not see other objects, even though some of your classmates could see them. You also looked into the end of a light box and learned that sometimes you could see what was inside, and sometimes you could not.

Your class used these activities to develop a list of conditions that need to be met in order for humans to see an object. As you read, think about these conditions and how they affect what you see on a television.

### *A Different Experience with Seeing: How Do I See Objects on Television?*

If you have a television in your home, turn it on. What do you see on the screen? You probably see a person, some objects, or a scene indoors or outdoors. However, there is a difference between seeing the actual object and seeing the object on television. To see the object—like a chair—in real life, you need a source to provide light, and you need the light to bounce off the chair to your eye. To see a chair on television, you do not need an additional source of light to bounce off of the chair.

The television is the light source. The television produces light that goes directly to your eyes. An image on television is both an object and a light source at the same time. That is why you can see objects on television even in a room with no lights.

Look at your activity sheet from Activity 2.2 to review your list of conditions people need to see. Explain what is different about seeing an object in a room and seeing an image on television. Use the list of conditions in your explanation.



The difference between seeing an object and an image on television is that an object must have a light source that is bouncing light off of it for us to see it. When we see an image on the television, the image is both the object and the light source. Point out to students that this is true for any light source; this is true for any light source. If you look at a light bulb, it is both the object and the light source.

### *How Is an Image on Television Similar to the Picture at the Beginning of This Reading?*

When you see objects on television, you are really seeing many tiny dots. Together, the dots create an image that looks like something real. These dots are called pixels. On some televisions, especially old ones, you may be able to see the pixels if you look at the screen closely. Even if you can see the pixels up close, they are too small to be seen as individual dots when you stand far away. Instead, your brain will put them together to make an image. This is the same way that the picture in the Getting Ready section works. If you stand far enough away, the tiny pictures look like pixels, and your brain puts them together to make a larger image.

### *An Example of Pixels*

When you see an image on your television or on a movie screen, you are actually seeing millions of tiny dots that all together look like the object or person. Your brain puts the dots together so that you see a single image.

Your television screen is a collection of tiny dots that join together to make the big picture you see. Each little dot acts like a light source and an object. The light moves along a straight path to your eyes. Your brain does not see a bunch of little objects, because it puts them together to see the image on the television.

### *Two More Examples: Newspapers and Artwork*

Dot patterns are not only used for television images. Dots are also used in computer and newspaper images and in paintings. If you have a newspaper at home, look at it very closely. If you have a magnifying glass, use it to look at the newspaper up close. Can you see the tiny dots that make up the pictures and the words? What do you notice in the photo of a flower and in the closeup of the photo next to it?



Many things in the world today use pixels to make images. Long ago, artists in France painted in a style called pointillism. Images using pointillism are created by painting many tiny dots or points. The colors of the paint are not mixed together using a brush. Instead, the different colored dots are placed very close together. When you look at the painting from far away, the light from the room bounces off the dots on the painting and then enters your eye. Your brain blends the dots together to form a larger image.

Compare the dots used in pointillism with the dots created on a television screen. Be sure that your comparison describes what is alike and what is different.

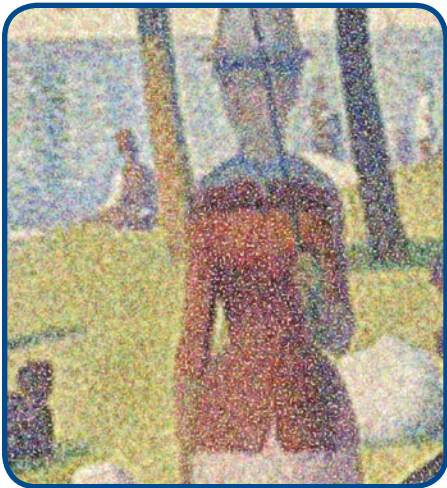

*Sunday Afternoon on the Island of La Grande Jatte,*  
Georges Seurat

## LESSON 3

# Constructing Models of How People See

### ACTIVITY 3.1 – PREPARING TO DEVELOP MODELS

#### What Will We Do?

We will construct physical models of how people see. Our models will represent the key components and relationships that we have learned so far.

#### Part A: Evaluating a Model

A model can be good or not-so-good, depending on what it is being used for. When you use a model to explain an idea to someone, the best model is usually a simple one. A good model for explaining something includes all the key components and the relationships between them. It is important that a model only includes those things and not extra parts that do not help explain something. It is also important that your model is accurate. You should look carefully at your model to be sure you have represented the components and the relationships correctly. Your teacher showed you a model of light using a clay light bulb and some toy cars.

1. How can you use this model to explain how people see?
2. How could you improve this model of light? Think about the components and the relationships between them. For each part of the model, ask yourself if you could explain how people see without considering that component. Also ask yourself if there is some part of seeing that your model does not represent.



## **Part B: Plan Your Model**

3. A model needs to be consistent with all the evidence. In Lesson 2, you gathered evidence that a model of seeing needs to include four key components: a light source; an object; an eye; and paths between the light, the object, and the eye. Look at the supplies your teacher has provided. What will you use to represent each of these parts?

## **Part C: Build and Evaluate Your Model**

4. No model is perfect. Every model has strengths and weaknesses. What are the strengths and weaknesses of your model?

5. What did you learn as you made your light model?



## Reading 3.1 – Modeling

### Getting Ready

Before you read about modeling, this short activity will get your brain working. First decide whether you agree or disagree with the following statements. Then check the appropriate boxes on the left.

Before Reading			After Reading		
Agree	Disagree		Agree	Disagree	
<input type="checkbox"/>	<input type="checkbox"/>	Models can change when people learn new information.	<input type="checkbox"/>	<input type="checkbox"/>	
<input type="checkbox"/>	<input type="checkbox"/>	There is one correct way to model a phenomenon.	<input type="checkbox"/>	<input type="checkbox"/>	
<input type="checkbox"/>	<input type="checkbox"/>	All models have both advantages and disadvantages.	<input type="checkbox"/>	<input type="checkbox"/>	

As you read, try to learn the answers to these questions about scientific models. After you read, come back and check your answers.

### Why Do Scientists Use Models?

When you hear the word *model*, you might think of fashion models or model airplanes or model cars. Scientists use the word *model* in a special way. In science, a model is a way to represent an idea, process, or system in order to describe, explain, or predict something.

Models help to explain things that are difficult to understand or difficult to observe. For instance, you cannot see your heart, but you can use a model of a heart to explain how it pumps blood through your body. Models can also represent things that are too big or too small to observe. People cannot observe the whole Earth at once, but they can use maps and globes as models to help them explain phenomena. People on television use maps to help them explain weather or earthquakes. Globes can help explain why it is day and night at different times in different parts of the world.

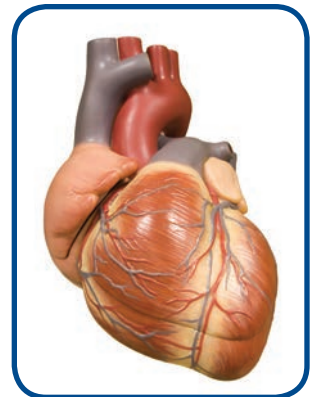

In class, you have been developing a model of how light makes it possible for people to see objects. Your model helps you understand, and it can also help you explain it to other people. Scientists use models to communicate. As you learn more about light, you might decide that you need a different model than the one you made today. Scientists revise their models as they learn new things. It is OK if your model of how people see gets revised, too.

Models help scientists think about possible answers to their questions about phenomena. You will use your model of seeing to explain how you could see the strange images in Lesson 1.



### *Is It OK that My Friend's Model Is Different from Mine?*

You and your classmates may have constructed different models of how people see. Different models can be helpful because they may show different information about the same phenomenon. All models have advantages and disadvantages. Even good models can often be made better. You will be learning how to evaluate models to decide what is good and what needs to be changed.

Scientists evaluate their own models and revise them when necessary. For example, new data make scientists think about a phenomenon in a new way. *Data* is a word you will use over and over again in science. When scientists make observations, they take careful notes while they are observing something with their senses or measuring it with instruments. The notes they write or record are called data. When they use data to support an idea, they are using the data as evidence. You will do the same thing in science class. Your data may come from your own observations and measurements, or it may come from a table or graph that someone else made. When you use data to explain an idea, you are using the data as evidence. When scientists—or you—develop a model, the model needs to be consistent with all the relevant evidence.

### *An Example of Scientists Revising Their Models*

Scientists revise a model when it does not work very well for explaining something. For example, you probably know that sailors once explored the world by sailing across oceans. They drew maps of the oceans and land to show what the world looked like. These drawings were similar to the flat maps we use today. Maps are one kind of model that is drawn. A flat model helped early scientists understand most things about the world around them.

However, as people made observations and tried to answer new questions, they found that a flat model of Earth did not work for everything. For example, sailors could see the tops of masts as ships approached them over the horizon. If Earth was flat, that would not make sense. They would not see the tops of masts first and then gradually see the rest of the ship. They also wondered why the sun changes its position in the sky throughout the year. A flat model of Earth was not consistent with the data they observed.

Scientists began to consider a new model. They began to use a round model of Earth—like a ball. A round Earth model can explain why the tops of ships' masts are visible first. A globe model can explain the positions of the sun in the sky, and it can explain seasons.

Later, photographs taken from space showed the shape of Earth. Before scientists knew for sure, they had to keep testing their model to see whether it worked to explain their observations. Today, a globe serves as a good model for many things scientists want to explain. A flat map is good for showing how to get from one place to another. However, it is not good for explaining how the sun rises and sets or how a ship can sail around the world. Every model has advantages and disadvantages.



A model that explains what you know today about how light helps people see might not be a good model for what you will try to explain later in the unit. You might revise your model as you gather more data. Scientists revise their models, and you can revise yours, too.

*Check Your Understanding*

Go back to the statements in the Getting Ready section. Now that you have finished reading, use the column on the right to check whether you agree or disagree with each statement.

## ACTIVITY 3.2 – BUILDING THE CONSENSUS MODEL

### What Will We Do?

We will combine the parts of our models that we agree about into one model called a consensus model. The consensus model will be a diagram instead of a physical model.

### Questions

1. Models have advantages and they have disadvantages. What did you think were the best parts of other students' models? Why?
2. How does your drawn model compare with the consensus model your class created? Describe what is similar and what is different about them.
3. Use your class consensus model to explain why you cannot see your grandma in the other room.
4. What do you still need to know about how light helps you see? What do you still want to know about how light helps you see?



## Reading 3.2 – Faster than a Speeding Bullet

### Getting Ready

In this reading, you will learn about how fast light moves. Before you read, think of some of the fastest things you have heard about. Fill in the chart with your ideas.

Moving Object	What/Who Is It?	How Fast Does It Go?
Fastest human runner		
Fastest bicycle rider		
Fastest animal		
Fastest car		
Fastest man-made object		

When people say that turning on a light switch lights up the room, what do they mean? In class, you constructed a model that shows what is needed for people to see objects in a room. The key components in your model were an object, an eye, a light source, and the key relationship between these was the straight paths between them. When you turn on a light bulb, light travels from the bulb outward in all directions and hits objects in the room. You see the objects because light travels from the light bulb, bounces off the objects, and then enters your eye.



If light has to travel back and forth across the room before you can see an object, why do you see things in a room as soon as you turn on a light switch? The answer has to do with the speed of light. Light is very fast. You will read about how scientists figured out how fast light is.

### How Do Scientists Measure How Fast Light Moves?

You do not have to wait to see things after you turn on a light, because light moves so fast. You do not even notice light moving. It probably seems like light gets from a bulb to an object and back to your eye instantly. If light moves so fast, how can scientists measure it? A famous scientist, Galileo, tried to measure how fast light moves.

Galileo wanted to measure the speed of light in the early 1600s. To do this, he sent an assistant to the top of a hill with a lamp. He wanted to measure how much time it took for light to travel from one hilltop to another. The assistant recorded what time it was on his watch as

he turned on his light. Galileo, standing on another hill, turned on his light immediately after he saw his assistant's light. The assistant then recorded the time at the instant he saw Galileo's light. Galileo's idea was that the assistant would have measured the time it took light to travel from one hill to the other and then back again. However, this did not work. The time it took Galileo to turn on his light was actually much longer than the time it took the light to travel from one hill to the next.

When Galileo first tried to measure the speed of light, he and his assistant stood on hilltops with lamps. Why was it necessary for them to be standing on the top of hills to conduct their experiment? (Think about the four conditions needed to see an object.)



Using the consensus model you and your classmates constructed in class, explain how Galileo could see his assistant's light. This can be done by showing how the key components in the model represent what was involved in Galileo seeing his assistant's light.



### *What Do We Know about the Speed of Light Today?*

In his experiment, Galileo and his assistant were several miles apart. Today, humans can send objects much farther away. In 1969, the United States sent astronauts to the moon. The moon is about 240,000 miles away from Earth. This is like traveling around the whole Earth 10 times. Think about how long it would take you to drive around the earth in a car. During the mission to the moon, scientists noticed that it took about one second for light from Earth to reach the astronauts on the moon.

Light can travel around Earth 10 times in just one second. Nothing else can travel that fast. The sun is much farther away than the moon. Traveling to the sun would be like taking 37,000 trips around Earth. Even though Earth is a huge distance from the sun, it only takes light from the sun about eight minutes to get to Earth. This means that when you see the sun, you are seeing how it looked eight minutes ago.

### *How Does the Speed of Light Compare to Other Fast Things?*

In the beginning of this reading, you thought about some fast things. The world's fastest people can run at about 25 miles per hour. A cheetah can run 70 miles per hour. The fastest animal is the peregrine falcon. It can fly over 200 miles per hour.

Humans have made machines that can move extremely fast. The fastest a person has ever made a bicycle go is 167 miles per hour. A Thrust SSC, the world's fastest car, can go 760 miles per hour. The fastest human-made objects travel in space. A spacecraft called the

Helios traveled at 150,000 miles per hour. At this speed, it would take about a month to travel from Earth to the sun.

It only takes light eight minutes to travel from the sun to the earth because light moves much faster than anything humans have ever made. Light moves through space at 670,000,000 miles per hour. This means that it would take a jet airplane 25 days to travel the same distance that light can travel in one second. When you flip on a light switch, it seems that light hits your eye instantly because light moves so fast. It moves back and forth across the room so fast that you do not even notice it moving.

### *How Can the Speed of Light Help People Move Faster?*

One way that the speed of light matters to scientists is when they think about space travel. Right now, if people could travel to Mars with the space shuttle, it would take nine months to get to Mars. It would take another nine months to get back to Earth. Scientists at NASA are studying how to use new spaceships called solar sails. This is a photo of a solar sail. These ships could travel thousands of times faster than the space shuttle. The space shuttle is pushed by burning rocket fuel, but solar sails are pushed by light. That means they would be much faster. Experimenting with solar sails is one of the ways that scientists use their understanding of light to create something new.



As you have learned, light moves extremely fast, and it will be able to help people do things even faster. In Lesson 4, you will learn about what happens to the light that enters your eye.



## LESSON 4

# The Eye as a Light Sensor

### ACTIVITY 4.1 – HOW THE EYE WORKS – OVERVIEW

#### What Will We Do?

We will learn about how our eyes act like a light sensor.

#### Procedure

1. Your teacher will project a representation of the eye. Use the following space to draw or write notes about what your teacher reviews in class.
2. You are going to go on a hunt using a light sensor. The sensor only detects light that comes from objects directly in front of it. The light has to bounce off the object or come from a light source and travel straight into the sensor.
3. In the drawings, where is the light that the light sensor detects coming from? Explain. Draw lines and arrows in the drawings to show the path the light travels until it enters the light sensor.

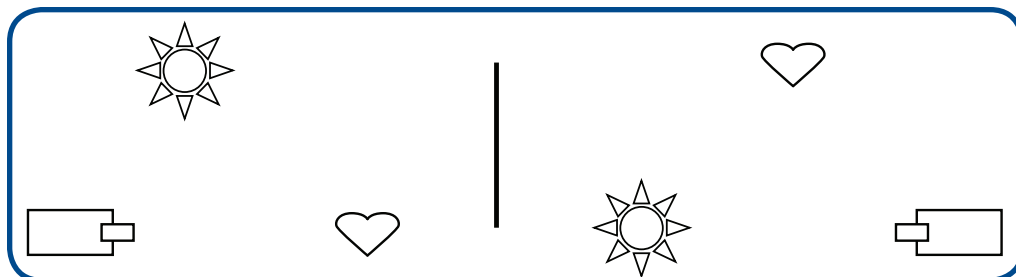



- Use the light sensor to measure light in different places in the room. Record the location, the measurement, and the units in the following table.

Location	Measurement on Data Logger

- Where are the brightest parts of the room? What range of values is shown on the data logger?
- Where are the least bright parts of the room? What range of values is shown on the data logger?

### *Making Sense*

- Like the light sensor, the eye acts as a sensor of light. Light has to come into the light sensor and into your eye from outside. How does the consensus model of light help to explain which parts of the room are the brightest (or the least bright) to the eyes?
- If no light is coming from any object into your eye, then what will you see? What evidence from a classroom activity supports your answer?





## Homework 4.1 – Exploring Shadows

### *What Will We Do?*

We will explore shadows inside or outside our homes.

### *Procedure*

If it is a sunny day, go outside and look for a shadow. In the following space, draw where the light source is compared to the shadow and the object that made the shadow. If possible, observe the shadow again an hour later. Compare the size, shape, and position of the two shadows. You could also do this activity using a shadow inside your home.

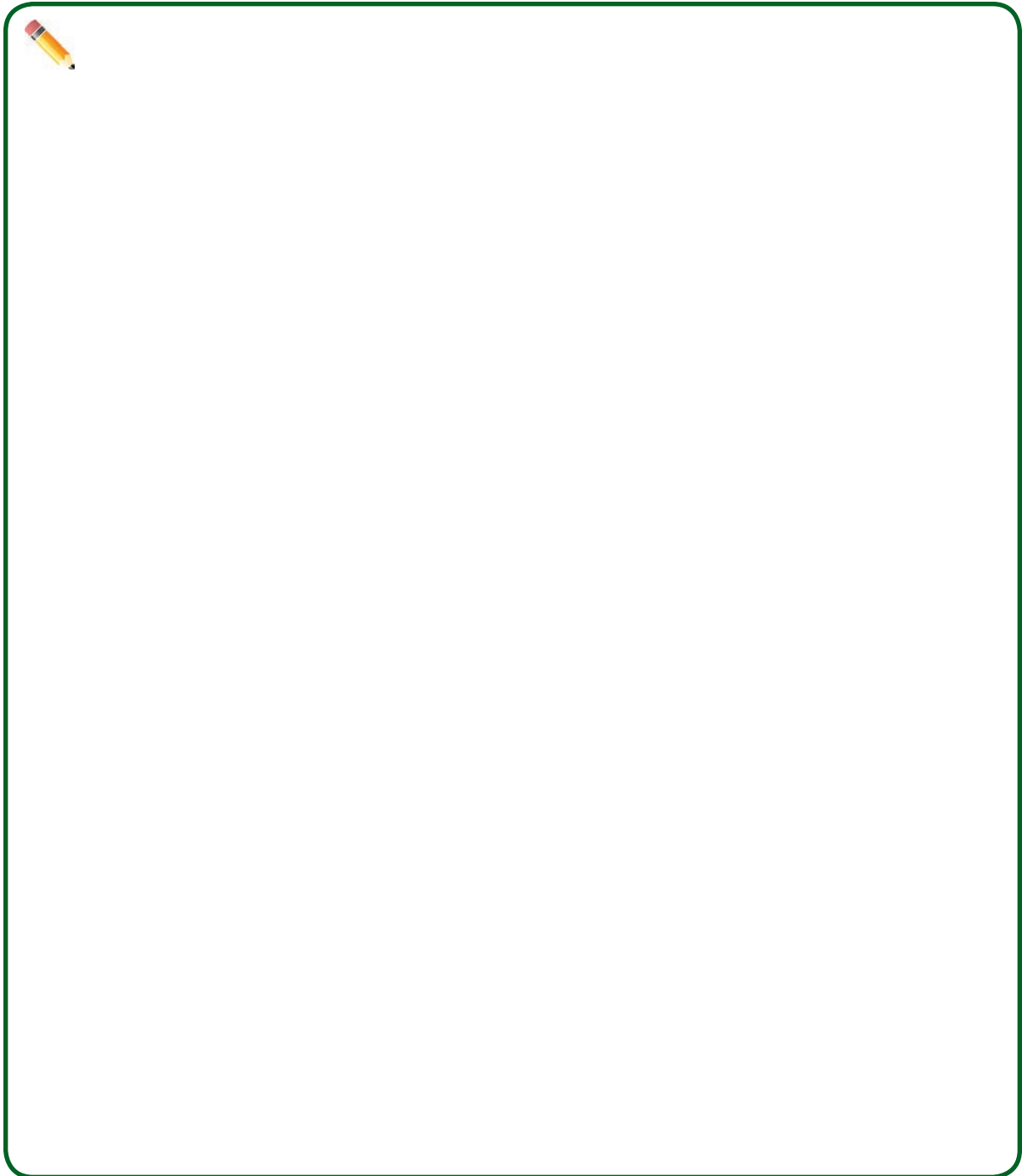



## Reading 4.1 – Eyes in the Animal Kingdom

### Getting Ready

Try this at home. Go into a small room with a mirror, like a bathroom. Look closely in the mirror at your eyes; then turn off the light and make the room as dark as possible. If you cannot make the room dark, shut your eyes and cover them with your hands. Wait for several seconds, and then turn the lights on as you continue to look at your eyes in the mirror.

What changes do you notice in your eyes immediately after you turn the light on? Why do you think this change happens?



Do you think the same change happens to animals' eyes? In this reading, you will learn why your eyes look different depending on whether the lights are on or off. You will also learn whether animals' eyes do something similar or different.

### How Do My Eyes Sense Light?

In class, you learned how the human eye works as a light sensor. When you see an object in a room, the light is bouncing off of that object and going straight into your eye. How does your eye help you see? The eye has several important parts. The opening in the center is called the pupil. In the picture, the pupil is labeled. It looks black, but it is really just like a clear window that lets light into the eye.

The cornea is a protective covering over the whole eye. It keeps the eye from getting scratched. The lens in the eye is like the lens in eyeglasses or in a camera. The lens focuses the light coming into the eye.

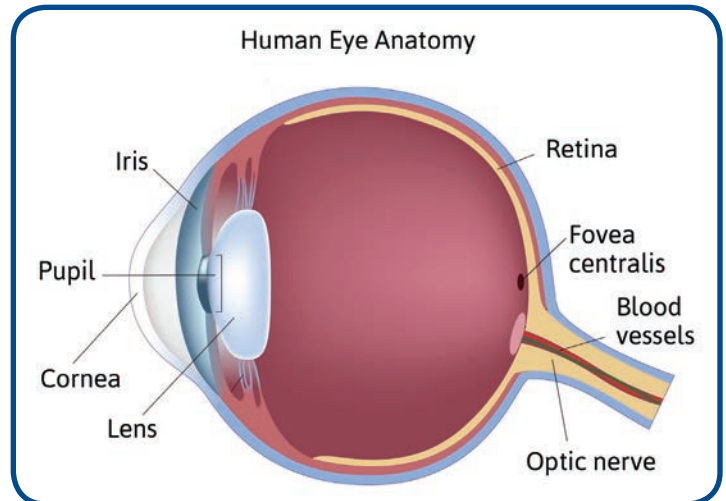

The lens focuses light onto the back of the eyeball on an area called the retina. Sensors in the retina detect the light that reaches them. Those sensors send a signal to the brain through the optic nerve.

### How Do the Parts of the Eye Work Together?

When you see a light bulb, several things happen. First, some of the light coming from the bulb enters your eye and reaches your retina. Second, your retina sends a signal to your brain. Third, your brain recognizes that the signal is a light from a light bulb.

Look at the diagram. If a coffee mug were in the room so that you could see it, then some of the light from the light bulb would be bouncing off of the mug. Some of the light bouncing off of the mug would enter your eye and reach the retina. A signal would go to your brain, and recognize it as the image of a mug. A lot has to happen for you to see something; but it happens very quickly.

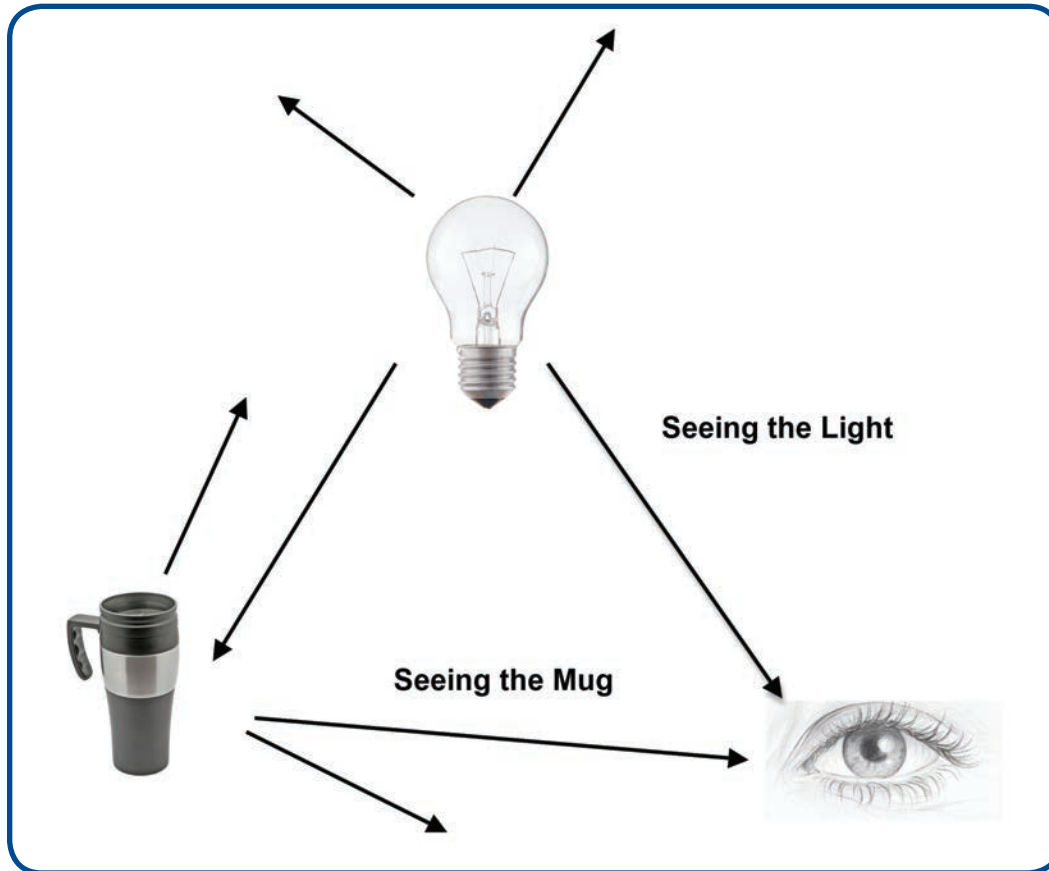

### *Using Equipment as a Light Sensor*

Your eye is a sensor. Special equipment also can act as a sensor. The light sensors that you used in this lesson are one example. When you pointed the sensor at an object, it detected the light coming from that object. Just like with your eyes or with cameras, light had to enter the sensor in order to be detected. Instead of sending a signal that your brain recognizes as an image, the light sensor sends a signal to a small computer. This computer receives the signal and displays a number that tells how much light is entering the sensor. When you saw an object in the room that looked bright to your eyes, the light sensor showed a very high number on its display. You may have gotten a high number when you pointed the sensor at the lights or at a window. When you saw an object that looked dim to your eyes, the sensor showed a low number on its display. You may have gotten low numbers when you pointed the sensor under tables or desks. When light enters a sensor, a computer gives information. When light enters your eye, your brain gives you information.

### *Do Animal Eyes Work like Human Eyes?*

Just like human eyes, animals' eyes work by detecting light. However, there are some differences between human eyes and some animals' eyes. In this reading, you will learn about three animals that have eyes with special characteristics.

#### Polar Bears

Have you ever played outside in the snow on a sunny day or played on a white sand beach on a sunny day? If you have, you know how bright it is when the sun's light bounces off of the white snow or the white sand. You also may have noticed that it is difficult to see in bright light without squinting. Why do people squint?



People squint so that their eyelids squeeze together and cover part of the iris. When the iris is partially covered, the path of some of the light going into the eyes gets blocked. Polar bears live outside in the snow. Because polar bears have to hunt for food in intense sunlight, their eyes have to allow them to see in very bright light. Polar bear eyes have a protective, clear cover over their eyeballs. The bears can see through this covering to hunt.

The covering protects their eyes from bright sunlight and the light that bounces off the snow. It is kind of like having built-in sunglasses. This protective cover also helps protect a bear's eyes when it swims under water.

#### Cats

Cats also have eyes adapted to their environment. As natural hunters, cats need to have keen senses in order to stalk their prey. Cats can see almost as well as humans during the daytime, but their nighttime vision is much better. Although cats cannot see in complete darkness, they can see much better than humans in environments that appear dark to us. In fact, cats can see six times better than humans in places with low light. There are several reasons for this. Cat retinas are more sensitive than human retinas. During the day, a cat's pupil looks like a slit. This slit decreases the amount of light entering the eyes and prevents the cat from having to squint. A round pupil, like in a human eye, would let in too much light.



At night, or when cats are in dark places, their pupils can open three times wider than those of humans. The wider opening lets in much more light. Like polar bears, they have a transparent protective cover over their eyes that allow them to see well in bright daylight. You may have seen a cat's eyes appear to glow in the dark when light is shined on them, as in the photo. The transparent cover causes cats' eyes to appear to glow at night. You may have also noticed this on dogs.

## Giant Sea Squid

This is a photo of a squid. Giant sea squids are known to have the largest eyes of any animal in the animal kingdom. Even though many animals are larger than the sea squid, none have such big eyes. Some giant sea squids have eyes about the size of your head. Their huge eyes have very large pupils that let in as much light as possible. So deep in the sea, where it is very dark, their eyes can let in the little bit of light that reaches them. Even squids or cats, which can see in very dark places, need some light to see. Even with large pupils, if no light enters the eye, then the animal will not be able to see.



### *Summarizing*

An important skill in any subject is summarizing. When you summarize something you have read, you tell the main ideas. That means thinking about what seems to be the most important ideas in what you read. In the following space, summarize what you have learned about animal eyes in today's reading. (Think about where they live and what their eyes need to be able to do for the animal to survive in its environment.) The beginning of a summary is written for you to get you started.

Different animals' eyes work in different ways. How their eyes work depends on the following factors:

A large, empty rectangular box with a green border, intended for writing a summary. A small yellow pencil icon is in the top-left corner.

## Wrapping Up

Show your understanding by filling in the blanks in the following sentences. In bright lights, the pupils of a human's eyes \_\_\_\_\_. In darkness, the pupils of a human's eyes \_\_\_\_\_.

Explain why the following sentence is not correct: Because cats have such good eyes, they can see when it is completely dark.







## LESSON 5

# How Are Shadows Created?

### ACTIVITY 5.1 – INTRODUCING SHADOWS

#### What Will We Do?

We will explore shadows and use our light model to explain our observations.

#### Procedure

1. The teacher will dim the lights in the classroom.
2. Put a piece of white paper on your desk.
3. Use your hand (or an object) and a flashlight to create a shadow on the paper.
4. Explore what happens to the shadow in three conditions:
  - a. moving the hand or object
  - b. moving the flashlight
  - c. moving the paper
5. Record your observations in the data table.
6. Discuss the following questions with your group:
  - a. How does the shape of the shadow compare to the shape of the object?
  - b. How can you change the size of the shadow?
  - c. How can you change the location of the shadow?

## Data

Conditions	Observation
Moving the Object	
Moving the Flashlight	
Moving the Paper	

## Making Sense

1. What parts of the light model do you need to explain how you see a shadow?
2. How does the light model help you explain that the shape of the shadow is like the shape of the object?
3. How does the light model help you explain how you can change the location of the shadow?
4. How does seeing an object compare with seeing a shadow?



## Homework 5.1 – A Midnight Crime

### *What Will We Do?*

Read a story about a crime that took place on a dark night. We will use what we have learned about light and shadows to answer questions and solve the crime.

### *A Midnight Crime*

Halloween was perfect with a clear and dark sky. Many people came to the Smiths' Halloween party. Everyone had a great time, and some people stayed until dawn. After everyone left, the Smiths discovered that some expensive jewelry was missing. They called the police. The police asked everyone who had been at the party to answer a few questions.

A police officer listened carefully to each person's story. Mr. Jones said, "I left the Smiths' party around midnight, and I walked to my car. It was cold, but the sky was clear with no clouds. It was totally dark outside. When I got in my car to leave, I saw someone walking out of the house holding a decorated wooden box. I turned on the car lights, and the person immediately turned around and walked away from me. He or she walked directly toward the wall next to the house. I could see the shadow on the wall getting larger and larger until the person disappeared around the corner. At that time, I did not suspect anything, so I just drove away." The police officer thought for a minute and said, "You are under arrest on suspicion of stealing the Smiths' jewelry. Your statement includes too many impossible details. I suspect you know something about the disappearance of the jewelry collection."

### *Follow Up Questions*

1. What are the impossible details in Mr. Jones's statement to the police? Explain why these details are impossible.

Detail in the Statement	Why Is That Impossible?

2. Construct a drawn model that helps explain how Mr. Jones would have really seen a person's shadow.

3. If Mr. Jones had not turned on his car lights, would he have been able to see the person? Would he have been able to see the person's shadow? Explain.



4. Explain why light is necessary to see an object.

## ACTIVITY 5.2 – CONNECTING SHADOWS TO THE LIGHT MODEL

### What Will We Do?

We will use the light model to explain how shadows are created and how we see shadows.

### Procedure

Look at the diagram. The diagram shows the consensus model with a new component added. Behind the object (the triangle) is a surface. The surface could be a piece of paper, a wall, or the top of your desk. The triangle represents any object that could make a shadow on the surface.

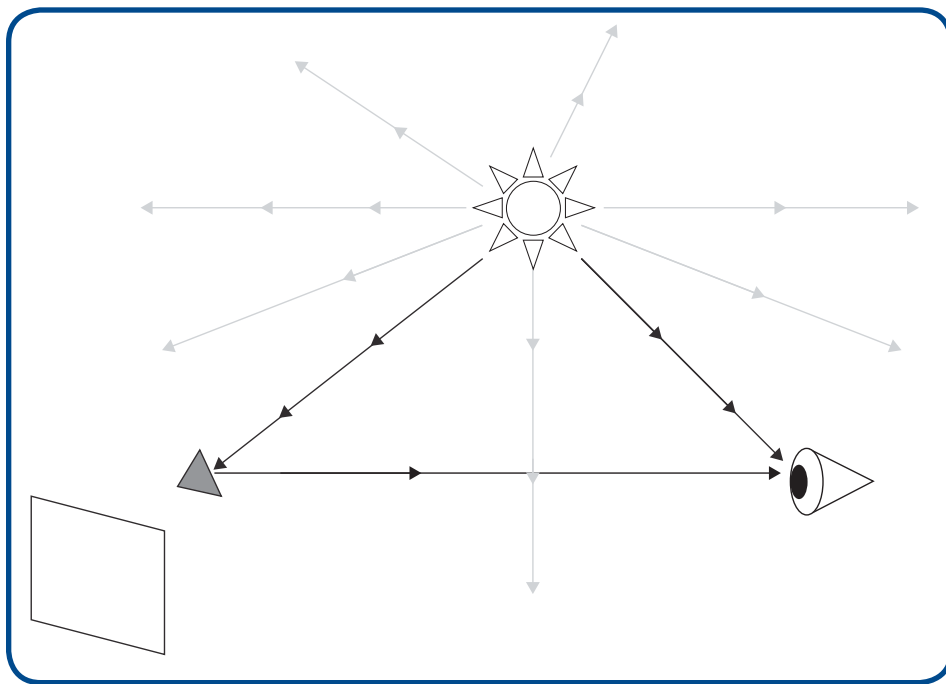

Construct a drawn model of how shadows are created and how you see shadows.

1. Draw the shadow of the object on the screen.
2. Add lines and arrows to your drawing to show how the shadow is created and how the eye sees the shadow.
3. Make sure your drawing includes all the components of the light model that represent the conditions necessary to see an object.

## Making Sense

Describe your model in a few sentences so that you could present your explanation to the class.



Use your model to answer the following questions.

1. What is similar between seeing an object and seeing a shadow?
2. What is different between seeing an object and seeing a shadow?
3. Models can be useful not only to understand and explain but also to predict something before experiencing it. Using your model, predict what a light detector would detect when pointing toward the shadowed area on the screen. Explain.



## Reading 5.2 – All Shadows Are Not the Same

### *Getting Ready*

Have you ever been outside on a sunny day and watched your shadow? Maybe you danced in front of a wall to watch how your shadow moves. Maybe you watched your shadow change as you got closer to a building. In this reading, you are going to do a few simple activities to learn more about shadows. All you will need is light and your own hand. As you do the activities, try to think about what is happening and why. You might be able to figure out some things even before you read about them.

### *Try This at Home*

Go into a room with a lot of lights and windows. Turn on all the lights, and hold your hand about six inches above a table or the floor. Try this during the day if you can. Look at the edges of your hand's shadow. Are they blurry or are they clear and straight?

Now, go into a room with no windows where you can turn all the lights off but one light on the ceiling. This should be a small light, not a long fluorescent light. If the room only has a desk or table lamp, you can use one of those instead. Hold your hand six inches above the table or floor again.

How does this shadow compare to the shadow you made before with lots of lights? Make sure to describe how both shadows are the same and different, paying special attention to the edges of the shadows.



What happens to the blurriness of the shadow if you move your hand closer and farther from the light? What happens to the shadow's size?





You probably noticed that your shadow was fuzzy when there were many lights on. Your shadow was less blurry when there was only one light on. In this reading, you will learn how the light model can help you explain why the edges of the shadow of your same hand looks clear sometimes and blurry sometimes.

### How Do I Make a Clear Shadow?

Before you learn what makes a fuzzy shadow, you should understand why some shadows have clear edges. In the Getting Ready activity, you saw that your hand had a clear shadow when there was only one light on.

In class, you used a light model to explain how a shadow is formed when a single light source shines on an object. You may have drawn something similar to the following example.

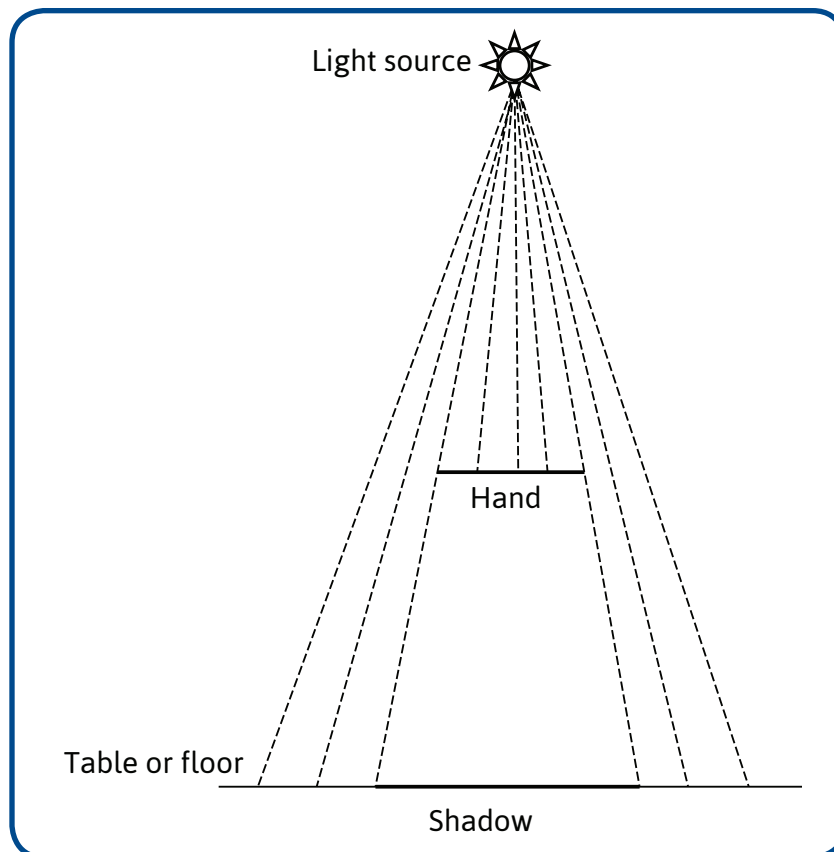

Light leaving a light source travels in straight lines. If a hand blocks the path between the light source and the table, then a shadow will be formed behind the hand. Why? Light that hits the hand will not get to the table. Light that misses the hand will get to the table. When every place on the table either receives light or does not receive light, the shadow has clear edges. There is a clear border between the lit and unlit areas (the shadow) on the table.

Look at the previous diagram. Notice how the diagram represents the light source, your hand, and the shadow on the table.

## How Can I Make a Fuzzy Shadow?

In the Getting Ready activity, you noticed that turning on more than one light source caused the shadow of your hand to be fuzzy. It might have caused the shadows to look like they overlap. You can understand why this happens by drawing the light model with two light sources. The following drawing shows the light model with two light sources. It looks like only Light source #1 is shining on the hand in the diagram. No light is coming from Light source #2 in the following diagram.

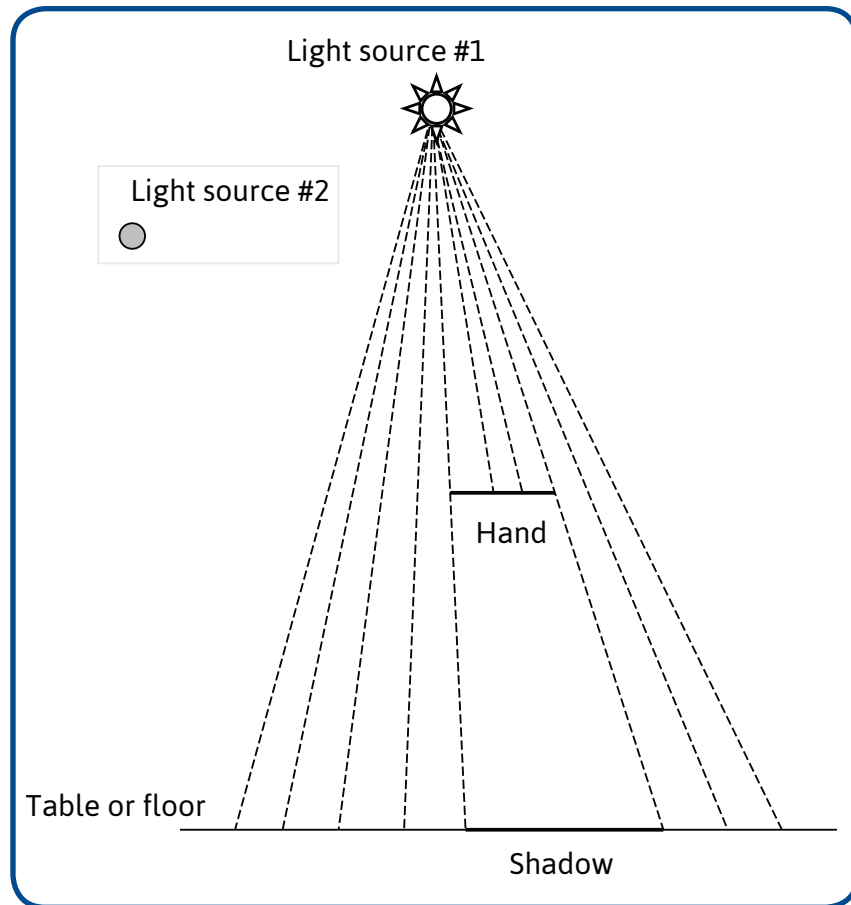

If only Light source #1 is turned on, there will be a clear shadow on the table or floor. However, something different happens when you turn on Light source #2 at the same time. Look closely at the following to see how the shadow changes.

The following diagram shows light from Light source #1 as dotted lines and light from Light source #2 as solid lines.

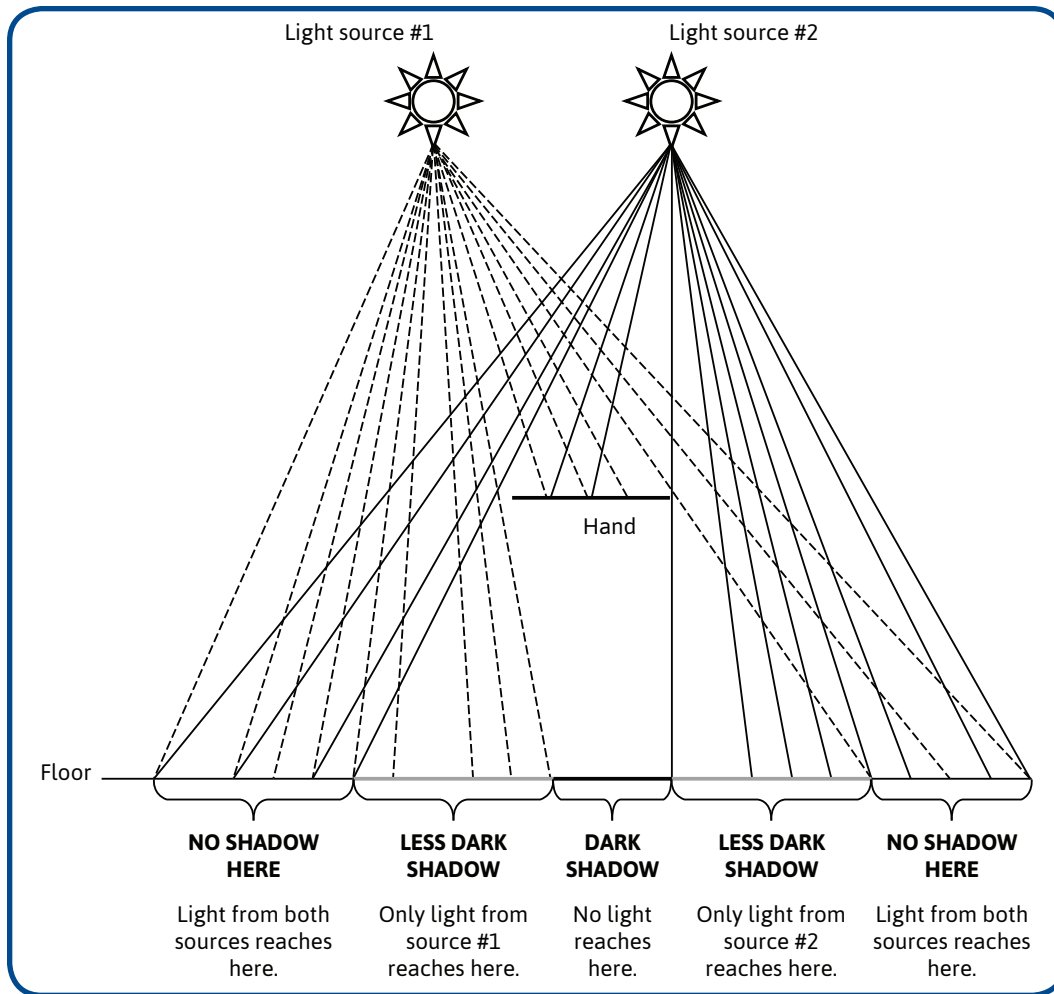

This drawing will make more sense if you think about each part of the drawing and about what you did. The table is represented by the line across the bottom of the drawing, but the lights are hitting your hand from different directions.

Can you see that the dark part of the shadow would be the part in the middle of your hand? No light from either light source gets through your hand to reach this area. The shadow there is dark, but next to it are areas that are lit by light from only one of the light sources, because your hand blocks the light from the other light source. These areas are less dark, but they are not bright. These areas are the part of the shadow that is gray or blurry.

### Another Example

The photo shows the shadow formed when two light sources shine on a ball on a stick. Notice that there is a very dark part of the shadow where no light from either light source reaches the wall. Notice that there are two less dark (or gray) areas where light from only one source reaches the wall. When there are two light sources, a shadow has darker and lighter areas. The dark area is where no light from either source reaches the wall. The areas that are not as dark are formed where light from only one source reaches the wall.

### *Comparing Shadows: One Light Source Compared to Two Light Sources*

Shadows are formed when an object blocks light from reaching something. You used your hand to block the path between the light and the wall or table. The picture shows a ball on a stick blocking the path between the lights and the wall. When there is only one light source, there is a clear border between the dark area and the light area on the wall. When there are two light sources, the dark area of the shadow is surrounded by areas that are not as dark. These less dark areas make the edges of shadows look fuzzy because they prevent a clear border between the very dark and very light parts of the wall. The more light sources there are, the fuzzier the edges of the shadow will look.

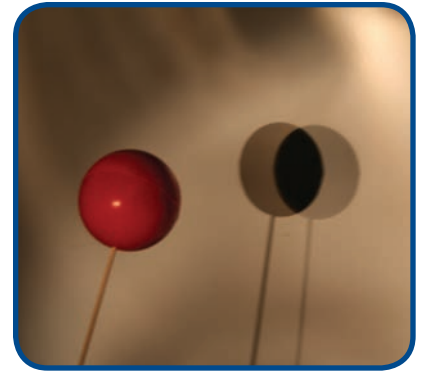

Why do you think the stick that is holding the ball is making two shadows? Why do you think that they are both gray instead of dark?



When you turned on many lights in the room and looked at your hand's shadow, why was the middle part of the shadow dark and the areas closer to the edge less dark?



### *Can a Shadow Be Fuzzy with Only One Light?*

You may have noticed that you could make the shadow of your hand look fuzzy with only one light turned on. This can happen if your hand is close to the light or if the light source is large and close to the object. The light model can help you understand why this happens, too. The next drawing shows how a shadow is formed using a larger light source. Light coming from the left side of the source is shown with dotted lines, and light from the right side of the source is shown with solid lines.

Instead of all the light coming from one place in the light source, light comes from everywhere in the light source. This is just like having several separate light sources, some at the top and some at the bottom. Lighter areas are formed when light from only the top or the bottom of the source can reach the wall. A dark area of the shadow appears where no light from anywhere in the source reaches the wall. Because the light from larger sources leaves from different places, they usually form fuzzy shadows.

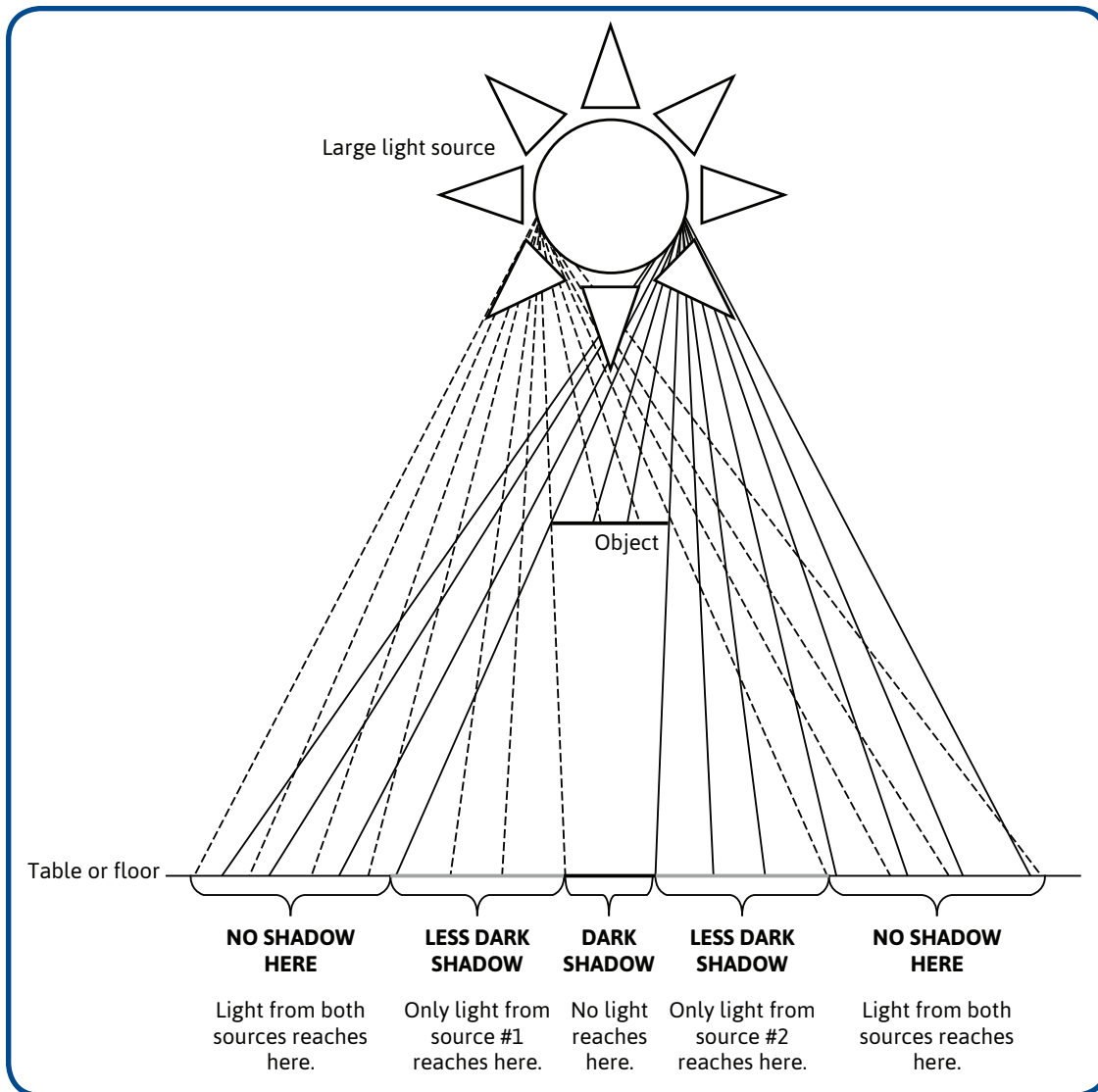

*When Can You See Shadows like This in Other Places?*

Have you ever seen a fluorescent (floor-eh-sent) light bulb? They are shaped like long tubes. You may have them in the ceiling of your classrooms at school. Shadows formed by fluorescent light bulbs will almost always be fuzzy because they are a large light source. Check the next time you are in school by holding your hand above your desk. You have probably noticed this fuzziness around shadows before. The model that you have developed through the first five lessons allows you to explain why this happens. Models are very powerful tools that scientists use to help them explain the world around them. Now you are using them, too.





## Reading 5.3 – Stars and the Solar System

### Getting Ready

Look at this photograph. What do you think is the picture? You might be surprised to learn that this is a photograph of galaxies. Each galaxy is made up of billions of stars. In fact, the universe has more than 100 billion galaxies, and each galaxy has about 100 billion stars. So there are a lot of stars. People can see only a very small number of them from Earth.

### Starry Night

Our sun is a huge ball of fire that radiates light. Stars are also huge balls of fire that radiate light, but they are much, much farther away, which is why they seem smaller. Like our sun, stars shine light in all directions.

Some of the light travels in the direction of Earth. Even though light travels very fast, most stars are so far away that it takes millions of years for their light to reach Earth. So when you see a star, you can see light that was produced millions of years ago. This means that when you look at the starry night sky, you actually look into the past. By the time light reaches you, the stars that produced it may have exploded or cooled down and died. It makes sense to assume that some of the stars you see do not exist anymore.

Planets, on the other hand, do not generate light. You see planets because they are relatively close to the sun, and they are lit by the sun. Light travels from the sun to the planets and then bounces off of them. Some of this light travels to your eyes here on Earth. Use what you have learned about light and sight to draw one or more models that explain

1. how you see stars.

2. how you see planets.



*Starry Night* by Vincent van Gogh

3. why you cannot see the stars or planets on a cloudy night.

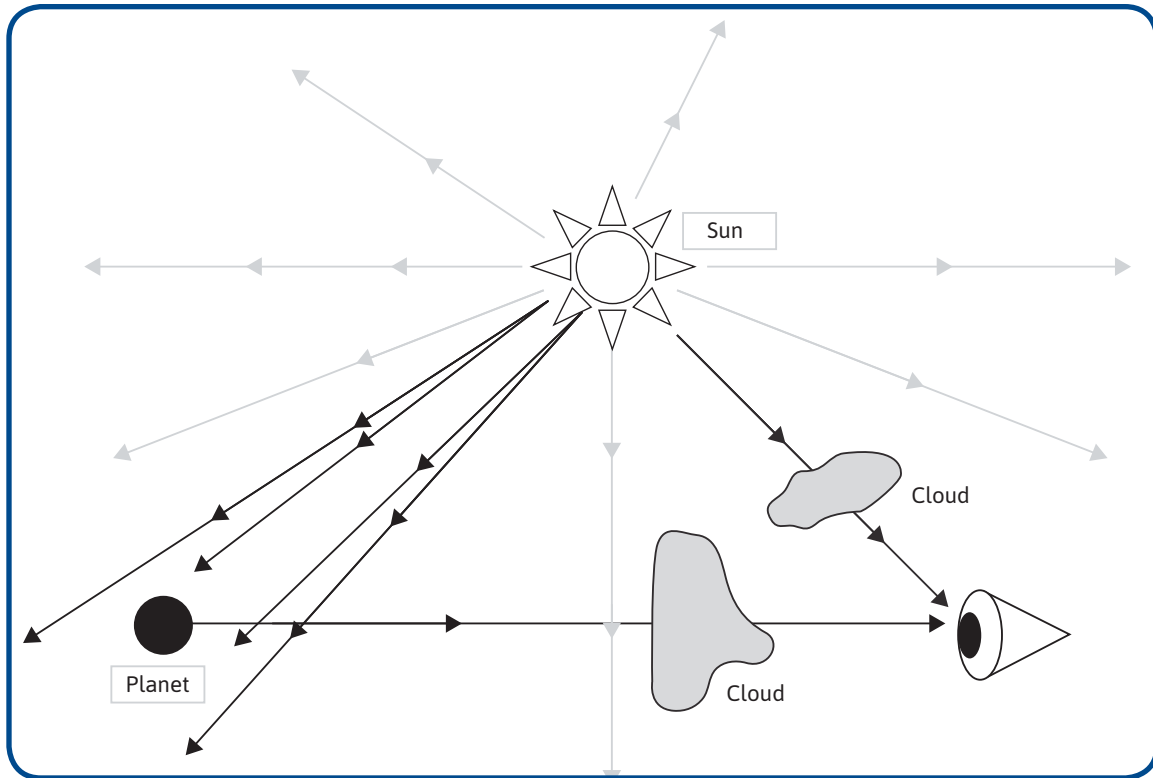

### *The Solar System*

The universe contains billions of galaxies, but most of the stars you see in the sky belong to the Milky Way galaxy. The Milky Way galaxy consists of hundreds of billions of stars, one of which is Earth's sun. People call it "the sun," as though there is only one. But the universe contains many other suns, too.

The Earth's sun is not at the center of the Milky Way, like it sometimes seems to be in pictures. The sun is actually off to one side. Eight planets, their moons, and other objects such as asteroids and comets, move around the Earth's sun. All these objects together are called the solar system. The sun is the

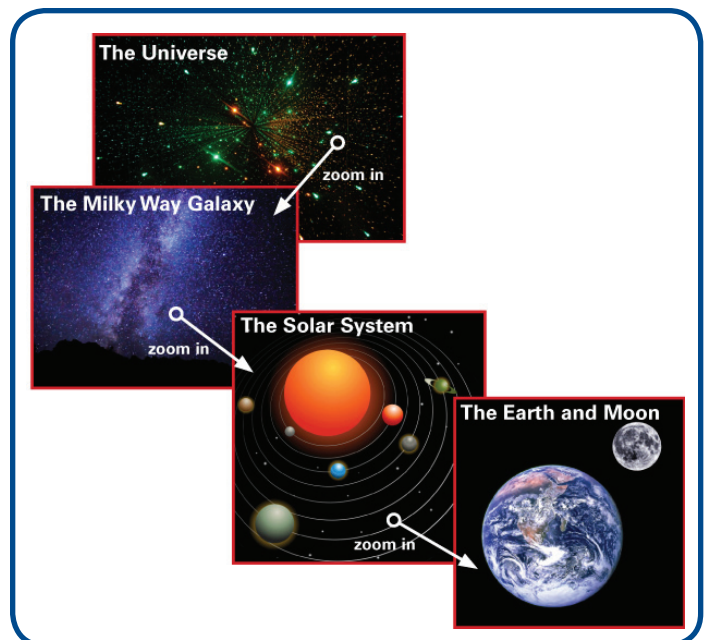



biggest object in Earth's solar system. It makes up more than 99% of the solar system's total mass. All the other objects in the solar system are arranged around the sun. The objects are constantly moving in orbits around the sun.

Look at the model of the solar system. It shows the position of the planets in relation to the sun and compared to each other. It also shows the shape of the path each planet makes around the sun. These paths are called orbits.

Like all models, this model has limitations. The relative sizes of the objects in the model are not accurate. For example, in this model, the sun seems about 50 times bigger than the earth, but it is actually more than 300,000 times larger than Earth. To represent the sun and the planets' sizes accurately, a model of the solar system would have to be bigger than your school.

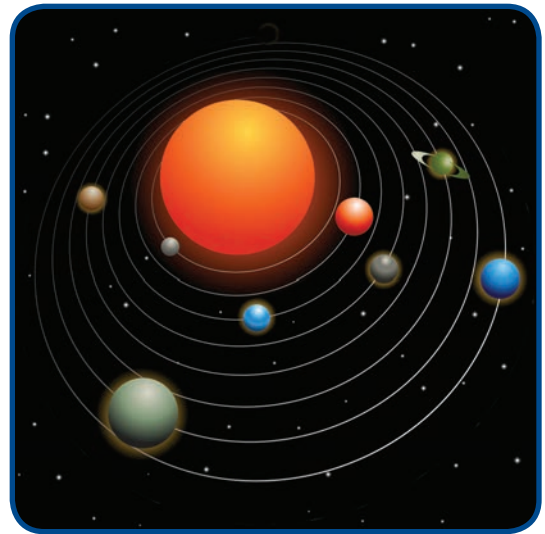

What else is not represented accurately in the model?

### *Do All Scientists Agree on This Model of the Solar System?*

Scientists used to think there were nine planets in the solar system—the eight that are in the diagram and Pluto. A few years ago, scientists decided that Pluto was not a planet. Why? Scientists believe that all the planets in the solar system originated from a huge cloud of gas and dust that used to surround the sun. For this reason, all the planets have many things in common. The shape of their orbits is one thing they have in common. However, Pluto's orbit is very different from the other planets' orbits. In fact, its orbit crosses Neptune's, so at times it is farther away from the sun than Neptune, and at other times it is closer. As scientists collect new evidence, they sometimes realize that what they thought before was wrong. They change their ideas and they change their models. This is an example of how science works. If you look around at models of the solar system, you might see some with nine planets and some with eight planets. Someday scientists may gather new evidence that will convince them that they need to change their model of the solar system again.

### *How Does Light Affect What I See in the Sky?*

When you look at the sky during the day, you can see the sun and sometimes the moon, but you never see the planets or the stars. This is because the sun's light is so bright that your eyes cannot detect much weaker light even though the weaker light also reaches your eyes. It is like going someplace where the music is loud or a crowd is cheering really loudly, and you cannot hear what your friend next to you is saying. Normally you could hear your friend, but the loud noise makes every other sound seem quiet. The bright light of the sun makes the light from the planets and the stars too weak for you to detect.

## LESSON 6

# Scattering and Reflection of Light

### ACTIVITY 6.1 – REFLECTION

#### What Will We Do?

We will investigate what happens when light strikes a mirror and bounces off of it.

#### Procedure

To do this activity, you will use the setup shown here.

#### Setup

1. Place the Angles sheet so that the thick horizontal line is along a wall or the side of a box.
2. Tape the paper down, so it cannot move.
3. Attach a flashlight to a ruler or a meterstick, so that the flashlight lens is about 30cm from the Angles sheet. If the flashlight can be focused, then focus the beam, so it is as narrow as possible. Be sure the flashlight points straight down the ruler, and the flashlight sits flat on the table.
4. Attach a light sensor to a different ruler or meterstick, so that the detector end of the sensor is about 30cm from the Angles sheets. Be sure the sensor points straight down the ruler and sits flat.
5. The flashlight beam should hit the wall (or box) directly above the dotted center line on the Angles sheet.
6. Use tape to attach a flat mirror to the vertical surface. Be sure the mirror is completely flat against the wall.

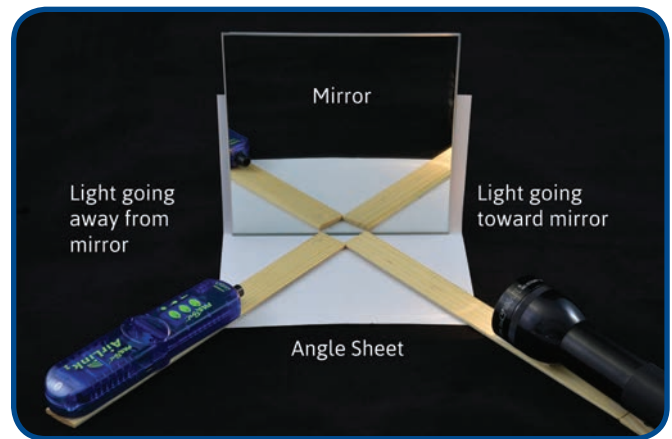

## Activity

1. Place the ruler and flashlight so the light shines directly at the mirror just above the dark horizontal line on the base of the Angles sheet. Position the ruler along Line 1 to the right of the dotted center line on the Angles sheet.
2. On the left side of the dotted center line, move the ruler with the light sensor around the point on the paper where all the lines meet. Move the sensor in this way until you find the position that gives the highest light reading.
3. In the data table, in the row for Position 1, draw the placement of the light sensor that gave you the largest reading. Record the number of the line that the light sensor is on. Write any observations you may have made as you found the biggest value.
4. Repeat Steps 1–3 four times, each time placing the flashlight on a different line to the right of the dotted line and keeping it in that place but moving the light sensor on Lines 1 through 5 to the left of the dotted center line.

## Flashlight and Mirror Data

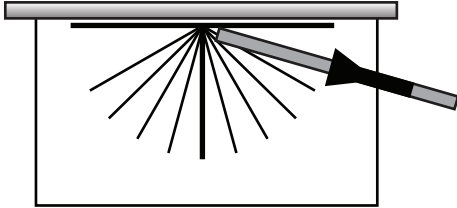
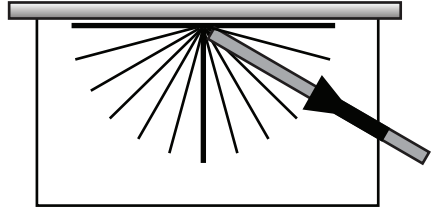
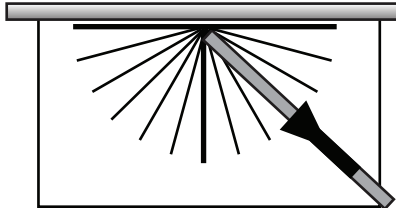
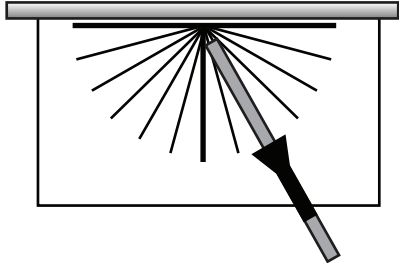
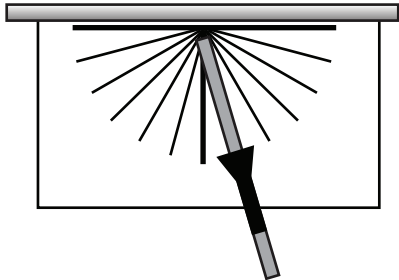
Position	Drawing	Comments and Observations
1		
2		
3		
4		
5		

## Making Sense

What patterns do you notice in the drawings you made in your table?



The following model shows light rays as they leave a source. Some of the light rays will hit the mirror. Based on what you learned in this activity about how light bounces off of a mirror, use a ruler to draw the path each light ray will take after it bounces off the mirror.

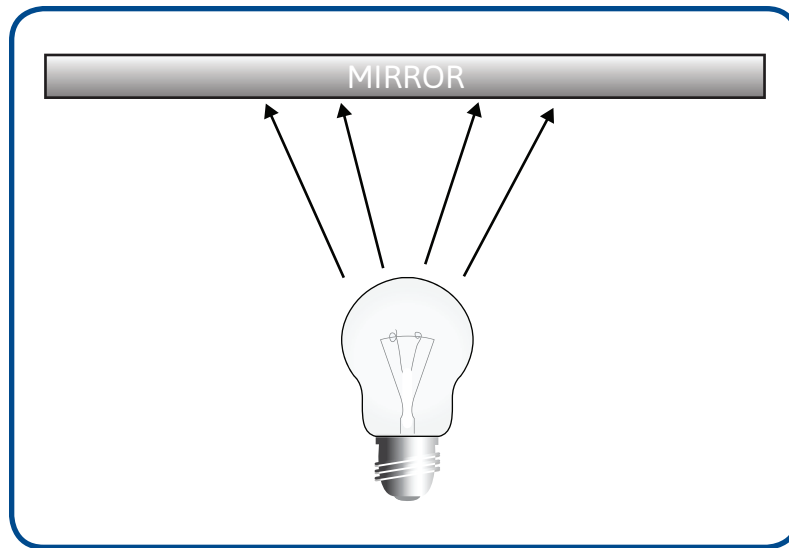

## ACTIVITY 6.2 – INVESTIGATING SCATTERING AND REFLECTION

### What Will We Do?

We will use a light sensor to investigate where light goes after it bounces off of two different surfaces. This investigation will help explain why a mirror looks different from a sheet of paper, even though light bounces off of both.

### Prediction

To do this activity, use the same setup that you used in Activity 6.1.

1. In Activity 6.1 you investigated how light behaved when it bounced off a mirror. How did the light sensor's readings change as you shined the light on the mirror and then moved the sensor from Position 1 through 5?
2. Based on the light model, what do you think the light sensor readings will show as you move the sensor from Position 1 through Position 5 when you shine the flashlight on a sheet of paper?

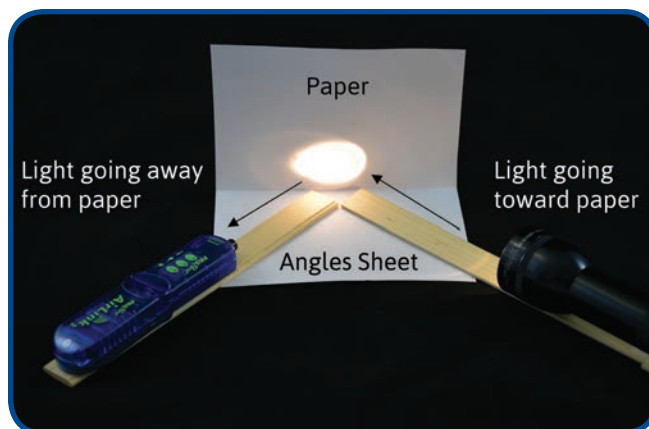

### Procedure

1. Prepare the setup with the flashlight, light sensor, mirror, and two rulers or metersticks just like in Activity 6.1. Use the Angle sheet again, as in Step 1 of that activity.
2. Place the meterstick with the flashlight along Position 3 to the right of the dotted center line on the Angles sheet. Tape this meterstick to the table so that it does not move during this activity.
3. Position the meterstick with the sensor at Position 1 on the left side of the dotted center line. Record the measurement from the light sensor in the data table.

4. Move the light sensor through each position (1–5) on the Angles sheet, and record each measurement in the data table.
5. After you complete the data table, remove the mirror and replace it with a piece of white paper.
6. Create a new data table just like the one you used for light bouncing off the mirror. Title the new data table *Light Bouncing Off of Paper*.
7. Repeat Steps 1–3 with the light shining on the sheet of paper. Record each measurement from Positions 1–5 in your new data table.

## **Data**

Create a data table to record and organize the data you collect about how light bounces off of a mirror.

Create a new data table to organize the data you collect about how light bounces off of paper.

## **Making Sense**

1. Compare the data you collected for the mirror with the data you collected for the sheet of paper.
2. How do your data compare with your predictions? If they are not the same, describe how your prediction was different from what you actually measured.
3. What is different about the mirror and the paper that could explain why the results were different for each object?

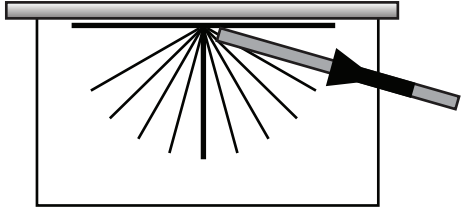
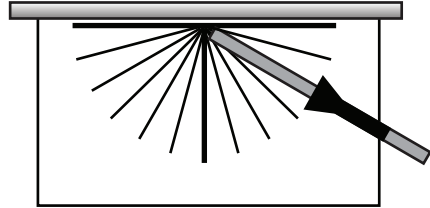
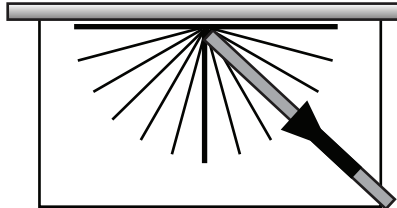
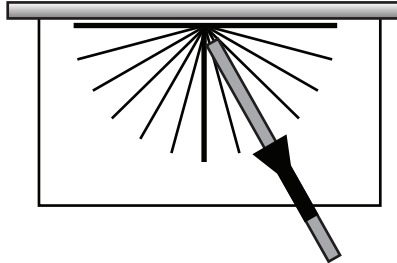
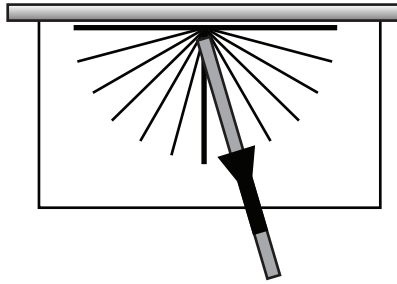

## Flashlight and Paper Data

Position	Drawing	Comments and Observations
1		
2		
3		
4		
5		



## Homework 6.2 – Scattering and Reflection – Part 1

Imagine that you shine a flashlight onto a mirror, as shown in the following image. Draw two different places where a person could stand so that light bouncing off of the mirror will reach them. Add rays to the model.

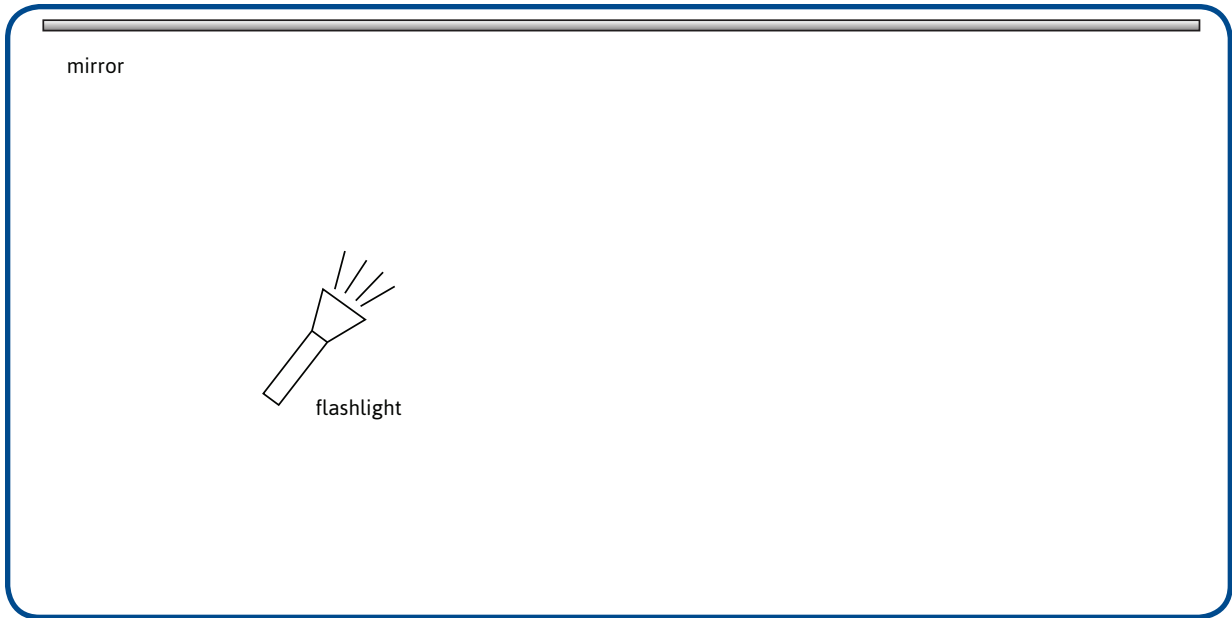

1. Explain why the person could stand in either of these places.

2. Imagine that you shine a flashlight onto a brick wall, as shown in the following image. Draw two different places where a person could stand so that light bouncing off of the wall will reach them.

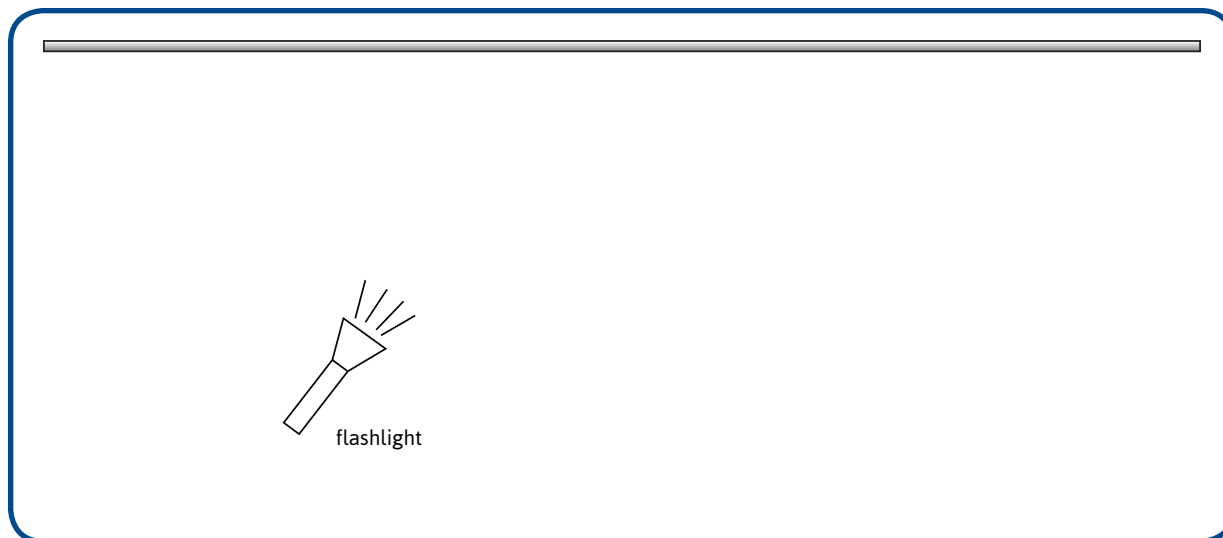

3. Explain why the person could stand in both of these places. Add rays to the model.

## ACTIVITY 6.3 – EXPLAINING SCATTERING, REFLECTION, AND IMAGES

### What Will We Do?

We will use our light model to explain why we can see an image of ourselves in a mirror but we cannot see ourselves in a sheet of paper or wood.

### Procedure

1. The following diagram shows what you see when your teacher covers part of an image with a sheet of paper. The diagram shows several light rays that have been given off by a flashlight. Based upon the light rays you can see, draw where you think the flashlight is located.
2. The following diagram shows what you see when your teacher covers part of an image with a sheet of paper. The diagram shows several light rays that have been given off by a flashlight. Based upon the light rays you can see, draw where you think the flashlight is located.

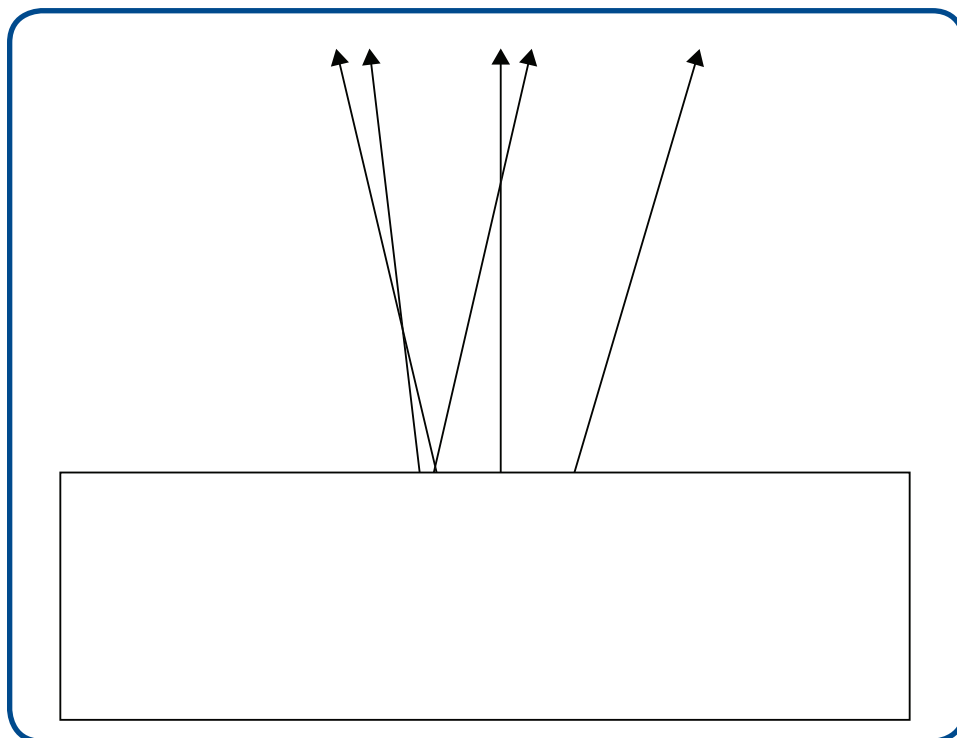
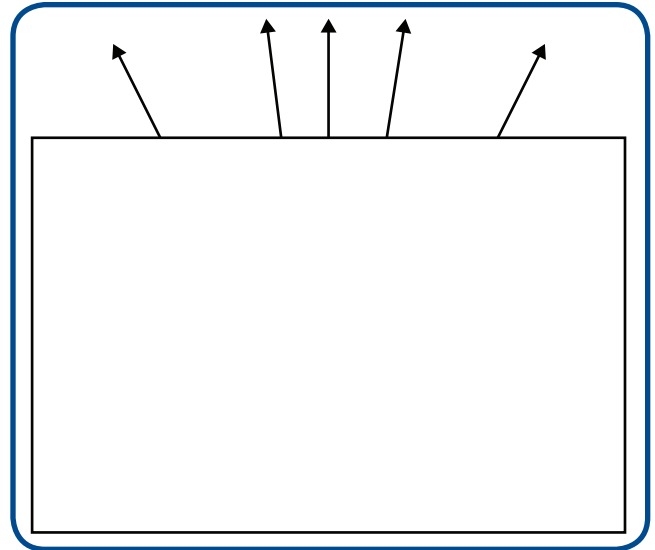

## Making Sense

Explain why you can see your reflection in a mirror but not in a sheet of paper.





## Homework 6.3 – Scattering and Reflection – Part 2

Explain what you have learned about scattering and reflection. Then apply what you have learned by explaining something that you see all the time but might not stop to think about.

1. What determines whether an object will scatter light or reflect light?
2. Why is it possible to see yourself in an object that reflects light, but not in one that scatters light?

The following two pictures show a car on a dry road and a wet road.



3. Using what you know about scattering and reflection, explain with words or drawings why it is possible to see an image of the car on the wet road but not on the dry road.



## Reading 6.3 – Polishing Objects

### Getting Ready

Look at this photograph. It is a photo of something magnified many times. When something is magnified, it appears much larger than your eye sees it by just looking at it. People sometimes refer to using your eyes with no magnifying glass or microscope as seeing with the naked eye. Before you read the hints, take a guess: What do you think this photo is?

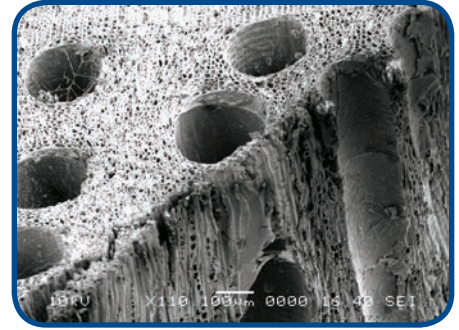

Here are four hints:

1. You can keep clothes in something made of it.
2. You may be sitting on it right now.
3. Baseball players use it.
4. It grows outdoors.

Did you figure out that this is a picture of wood? When wood is magnified many times, it looks like tiny tubes. Sometimes the surface of wood is shiny. A baseball bat might have a shiny surface. Maybe you have a table at home or in school with a surface that shines, but you cannot see your reflection in wood as well as you can in a mirror.

Why does your reflection in a mirror look different from your reflection in wood?



### *Why Can I See My Reflection in Some Objects but Not in Others?*

In class, you did an investigation using a light sensor to track light from a flashlight. You compared what the light did as it bounced off a mirror and off a sheet of paper. When light reaches a surface, it can be reflected or it can be scattered. You learned that after the light bounced off of a mirror, all of the light went in about the same direction. After the light bounced off of a sheet of paper, it went in many directions.

Reflection is what happens when light bounces off of a surface that is very smooth. A mirror has a very smooth surface. Look at the following two models. They show two different ways that light interacts with a surface.

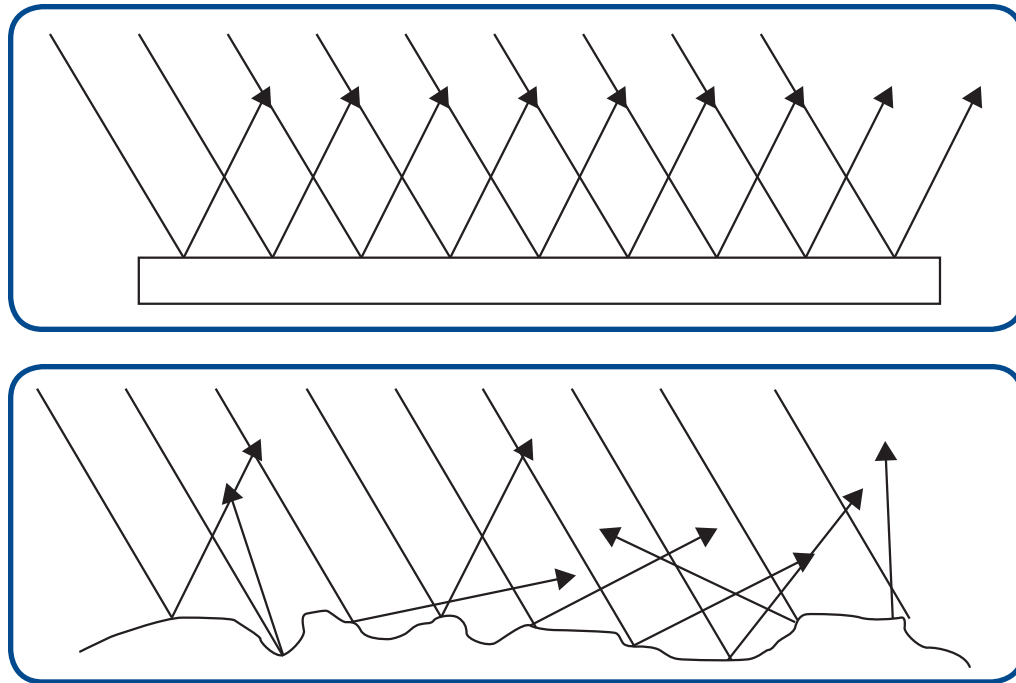

The model on the top shows light reflecting off of a smooth surface, like a mirror. See how all of the arrows point in about the same direction? Now, look at the model on the bottom. The arrows in this model point in many directions. This is what happens when light bounces off of paper. Paper seems smooth, but if you magnify the surface, like the photo of wood at the beginning of this reading, you can see that the surface is bumpy. Light bouncing off of a bumpy surface is scattered.

Scattering is what occurs when light bounces off of surfaces that are not smooth. Many objects that scatter light feel smooth when you touch them. A sheet of paper and a wooden baseball bat feel smooth. However, if you could look at them with a powerful microscope, you would see that their surfaces are bumpy.

If you could take an object that scatters light, like a piece of wood, and smooth out all the bumps and ridges, then the object would reflect more light and scatter less light. The process of smoothing the microscopic bumps and ridges on a surface is called polishing.

#### *How Does a Mirror Really Work?*

In class, you saw a model like this one. Your teacher covered the top of it and asked you to guess what was underneath the paper. You may have been surprised to see a flashlight pointing downward instead of a flashlight pointing upward. In this activity, you learned how you can see an image of something in a mirror. All of the light rays

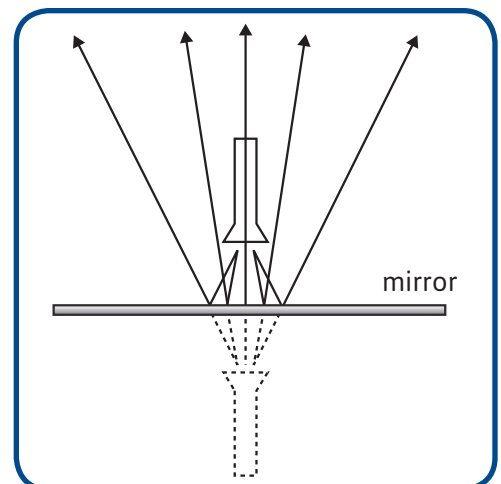



are reflected from a mirror so they bounce back to your eyes, and they look like they are coming from an object on the other side of the mirror. If the surface of the mirror is scratched, it will scatter more of the light that hits it. If the mirror is too scratched or uneven, so much light will be scattered that you can no longer see a clear image in the mirror.

### *Using Mirrors to See the Stars*

Astronomers are one type of scientists who use mirrors. Astronomers use telescopes to produce images of stars and planets that are very far away. Telescopes use specially curved mirrors to reflect light from stars toward a sensor. The sensor uses this light to produce a picture of the stars.

Many objects in the sky do not appear very bright because they are so far away. This means that very little of the light that comes from them actually reaches Earth. In order to get the best pictures, astronomers must use a big mirror that reflects a lot of light, so it helps to see even very faint objects. A smooth mirror produces a clear image because it reflects almost all the light to the sensor, scattering very little.



### *Polishing a Giant Telescope*

The Hale telescope at the Mount Palomar Observatory in California was the largest telescope in the world for more than 50 years. The main mirror in the Hale telescope is 200 inches across. An average 12-year-old is less than 60 inches tall. The mirror is about as big as three adults standing on top of each other. The mirror is very smooth. If you could magnify it so that it was as wide as the Atlantic Ocean, the biggest bump you could see on its surface would be smaller than 5 centimeters high. It is very difficult to make a mirror so smooth. It took about 11 years for people to polish this mirror by hand.



### *Other Things People Polish to Reflect More Light*

Polished mirrors are important to astronomers. You probably use polished mirrors, too. People polish other objects—like rocks—to make them look more shiny and pretty, as you can see in these photos.

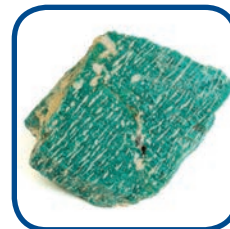

A device called a rock tumbler was used to polish the rocks in the photographs. A rock tumbler has a small barrel filled with rocks, water, and coarse sand. The barrel rotates slowly so that the coarse sand rubs over the surface of the bumpy rocks. Coarse sand smooths the large bumps on the rocks. Those are the bumps that you do not need a microscope to see. In the photo, it is easy to see the bumps on the stones on the left. After awhile, the coarse sand is replaced with finer sand. Sand that has a fine grain can smooth out smaller bumps that you cannot see or feel. After enough time in a rock tumbler, rocks and minerals appear much shinier than they were at first. Why? The polished rocks are smoother, so they reflect much more of the light that hits them.

### *What Makes Wood Look Shiny?*

Wood is polished in a different way. To polish wood, the surface is covered with a clear substance, like wax. The wax fills all the tiny holes in the wood. After the holes are filled, the wood has a smooth surface that reflects light much better. The following pictures show the difference between a wood floor with wax and one without wax.



### *Why Do People Polish Things?*

People polish surfaces for different reasons. They polish wood, rocks, and minerals because they like the way the finished objects look and feel. Materials like gold and diamonds are not very shiny before they are polished. The diamond and gold jewelry people wear has been polished. In science, polishing is an important part of making instruments like telescopes work properly. Instruments like these can help people learn more about the universe in which they live.



1. To polish leather shoes, people use shoe polish. What does this tell you about the surface of leather?
  
  
  
  
  
  
  
  
  
  
2. Most objects that can be polished still scatter some light; no object can have pure reflection without any scattering. Why?



## Reading 6.4 – Moon Phases

### Getting Ready

Can you imagine traveling in a spacecraft and then stepping out onto the surface of the moon? On July 21, 1969, the American astronaut, Neil Armstrong, became the first person to walk on the moon. As he put his foot down, Armstrong declared, "That is one small step for man, one giant leap for mankind."

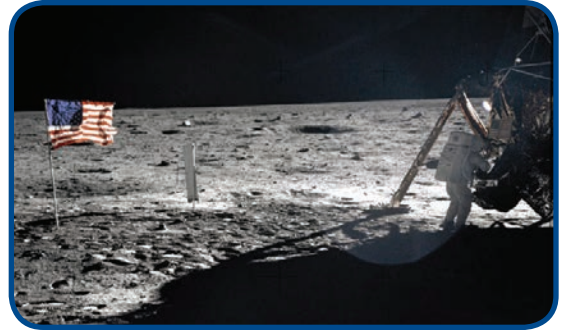

Armstrong is one of the few people who have been lucky enough to see how Earth looks from the moon. Most people only see how the moon looks from Earth. In this reading, you will learn how people see the moon from Earth. You will also learn why the moon's appearance changes every day. To understand this, you need to learn why there are days and nights on Earth.

### What Makes Day and Night Happen?

Every day you can see the sun as it seems to rise from the eastern horizon, move across the sky, and set in the west. What people sometimes do not understand is that the sun is not really moving at all. It only seems to move because the Earth spins around, carrying people in and out of view of the sun. You see the sun during the day because you are on the part of the earth facing the sun. You do not see it at night because the earth has spun so that you are on the side turned away from the sun.

Imagine that you are sitting on a chair that can spin, and a friend is standing beside you holding a candle. As you spin slowly in the chair, you first see the candle out of the corner of one eye, moving from the side until it is right in front of you. Then it seems to move to the other side until it disappears because it is behind you. If you did not know you were spinning, you might think that the candle was moving around you in a circle. The same thing happens with the earth and the sun. Instead of the chair, the earth is the object that is spinning. People are seated on the surface of the earth as it points them in the direction of the sun and then away from it. This same thing happens every single day. You experience sunrise and sunset because Earth spins on its axis. So actually the terms sunrise and sunset are misleading, since the sun does not actually move around Earth; it just appears to do so.

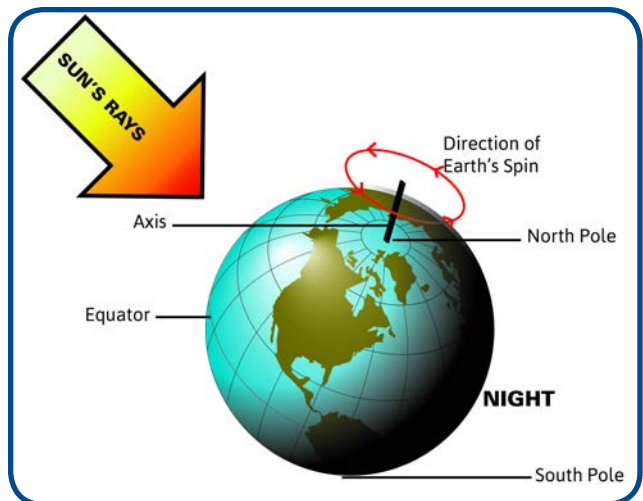

Earth's axis is an imaginary line that runs from the North Pole to the South Pole and through the middle of the earth. Earth completes a full turn around its axis once every day. That means it takes 24 hours for Earth to do a complete turn. Earth's spinning is the reason why people experience day and night. One half of Earth faces the sun and is lit up, so it is daytime there. At the same time, the other half of Earth faces away from the sun. The sun's rays are blocked,

so it is dark (or nighttime) on that side of the earth. As Earth spins on its axis, different parts turn to face the sun or to face away from it. This is what causes people on Earth to experience day and night.

### *Round and Round They Go*

At the same time that Earth spins on its axis, it also moves around the sun on a path called an orbit. Earth's orbit around the sun takes about 365 days (one year) to complete. At the same time that Earth revolves around the sun, the moon is also orbiting around Earth. A full orbit of the moon around Earth takes about 28 days (one month) to complete. These processes explain why people on Earth experience days and nights, the moon looks different at different times of each month, and people experience seasons. All of these are related in some way to light. This reading will focus on how people see the moon and why the moon's shape changes every day.

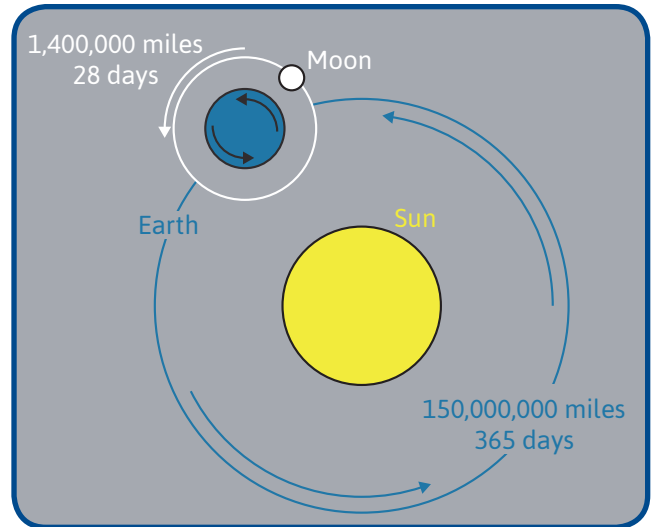

### *How Do People See the Moon?*

For you to see an object, it either needs to be a light source or it needs to be lit by a light source. The sun is a light source, which is why you can see it. The moon, on the other hand, is not a light source. Yet, you can still see it. The only thing that could be happening is that the moon is being lit by some other light source. Can you tell from the model what is lighting the moon so that you can see it? The light source that shines on the moon is the sun. Half of the moon is always lit by the sun, just like half of the earth is always lit by the sun. You can never see the dark side of the moon, because no light reaches it. If no light reaches it, no light can be scattered from it to your eyes.

Think about the four conditions needed for you to see an object. How are these conditions met in the case of seeing the moon from Earth? Look at the diagram to help you explain.

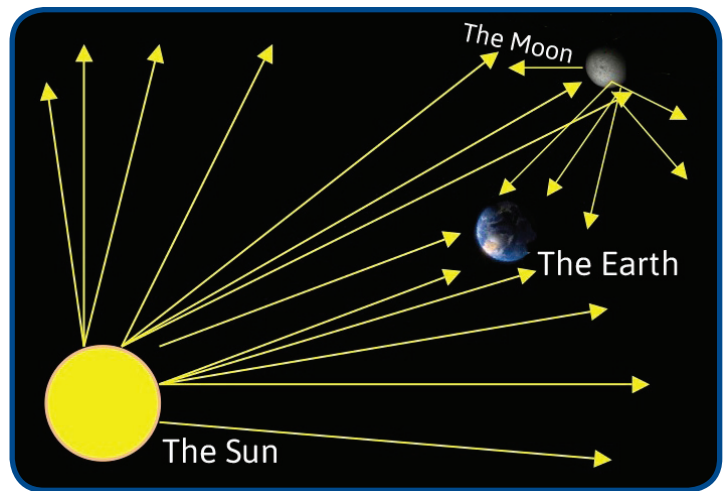
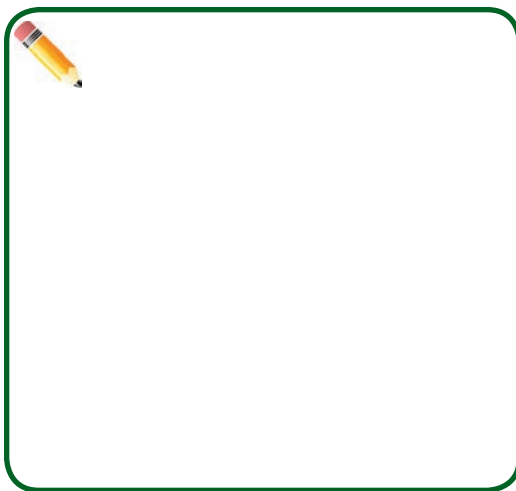

For you to see the side of the moon that is lit by the sun, some of the sun's light that is scattered by the moon needs to reach your eyes here on Earth.

### *Moonrise and Moonset*

When you are standing on Earth, the moon appears to move across the night sky just as the sun appears to move during the day. In fact, Earth spinning around its axis causes the moon to rise in the east and set in the west, just like the sun. Many times, the moon rises during the day instead of during the night. If we look closely we can see it, but we usually do not notice it. Why?



### *What Makes a Full Moon or a Half Moon?*

Depending on when you look at the moon, you might see a full moon, a half moon, a tiny sliver of a moon, or no moon at all. In fact, the moon is always there, and half of it is always lit by the sun. Whether you see it or not and what shape you see depends on the position of the moon in relation to the sun and Earth.

From Earth, you can only see the part of the moon that is facing Earth. This is not necessarily the part of the moon lit by the sun. This is why, most of the time, we do not see a fully-illuminated circle, but only part of it. The changing shape that you see is called a phase of the moon. The phase is the part of the moon that is both lit by the sun and seen from Earth. The phases of the moon change in a cycle starting with the new moon (also called the dark moon). Because it takes 28 days for the moon to go around Earth, the changing shape that you see repeats every 28 days.

Look at the model to see the cycle of phases and the names of each phase. Waning means shrinking, waxing means growing, and gibbous means swollen. You may choose to search on the Internet for video illustrating and explaining the moon's phases.

To better understand how you see phases of the moon, it might help to look at two phases more closely.

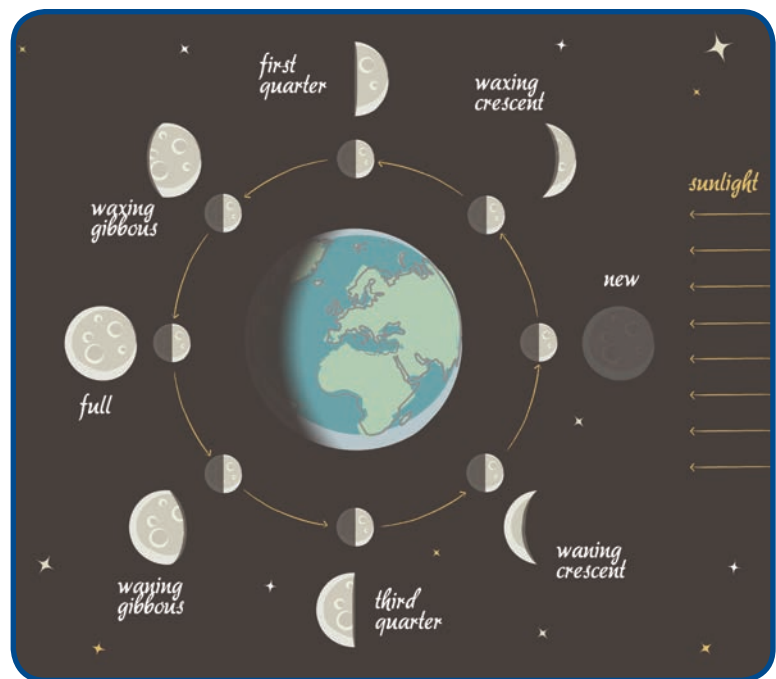



### *New Moon (or Dark Moon)*

A new moon exists when the moon is between the sun and Earth. At that point, the lit side of the moon is facing directly away from Earth, so you cannot see it. The side of the moon facing Earth is not lit, so it is dark. When you look in the night sky, you may think that there is no moon at all. The sun is reflecting off of the surface of the moon, but if you drew the arrows in the previous diagram, you would see that none of the light is reaching the eyes of people on Earth.

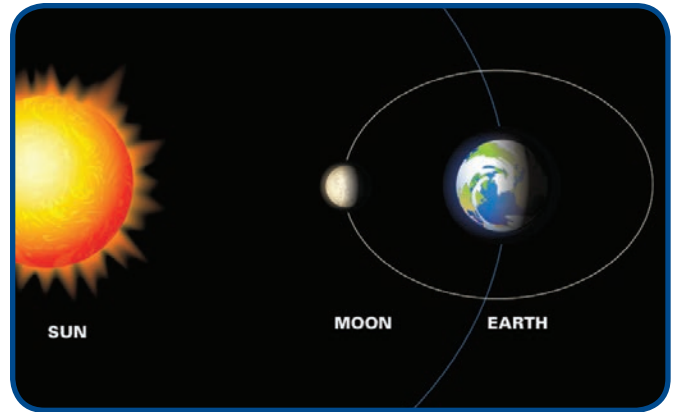

### *Full Moon*

A full moon exists when Earth is between the sun and the moon. It is important for you to notice the lines of the orbits for this to make sense. Remember that the moon is orbiting Earth; it is not orbiting the sun. When the lit side of the moon is facing Earth, you see a big circle of moon that is called a full moon. The dark side of the moon (the side that is not illuminated by the sun) is facing away from Earth.

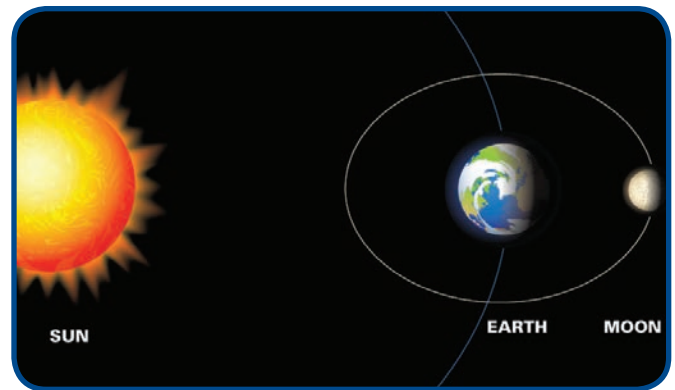

Because the cycle of the moon's phases repeats every 28 days, it is possible to use the previous models to predict the moon's phase on any given date. If you have access to the Internet, you can look up calendars of phases of the moon.

Draw a model explaining why the moon will look the way it will on your next birthday. If you are not sure, take a look at the models on the other pages in this reading. Instead of using the computer, you could also choose one of the moon's other phases (not a full or new moon) and draw a model to explain why it would look that way on Earth.



In this reading, you learned how to apply what you have learned about light to explain what the moon looks like from Earth. This is an example of how a simple model can explain many phenomena. In the next readings, you will use the same model to explain how an eclipse occurs.



## LESSON 7

# Transmission of Light

### WARM-UP ACTIVITY

#### What Will We Do?

We will investigate what causes the phases of the moon.

#### Procedure

##### *Part 1*

Pretend that a Ping-Pong ball is the moon. The skewer through the ball lets you hold it more easily, but it does not represent anything.

Objects we collected in order of most (1) to least (6) light transmitted as we look at them	
1	
2	
3	
4	
5	
6	

Since the position of the sun barely changes as the moon revolves around Earth, it is important that you keep the white half of the Ping-Pong ball (the side of the moon) facing the sun during this activity.





4. Put your arm in the same position you started in—straight out in front of you. Now, move it  $45^\circ$  to the right, keeping the white side facing the left, toward the sun. Draw what you see.

5. Now move your arm  $45^\circ$  to the right again. Your arm should be out to your right side. The white side of the ball—the lit side of the moon—should still be facing the sun. Draw what you see.

6. Look at Reading 6.4. Use the diagram to compare your drawings of the ball to the phases of the moon. Add the proper names to the phases of the moon represented in your drawings.

### *Part 2*

Three students will participate in the next part of the activity. One will sit on a swivel chair. This person will be Earth. Earth should revolve slowly to simulate Earth spinning on its axis. Another person will stand to the side, pointing a lit flashlight at Earth. That person will represent the sun. The teacher will darken the room.

1. Why is the flashlight a poor simulation of the sun?

2. Which side of Earth is in daytime and which side is in nighttime during this activity?



## ACTIVITY 7.1 – EVALUATING THE LIGHT MODEL

### What Will We Do?

We will evaluate our current model of light to see if it helps us explain why we can see through some objects but not others.

### Use the Light Model

In the following space, draw the light model to explain why you cannot see an object when there is a cardboard divider between your eye and the object.



### Prediction

1. According to the light model, what happens to light when it reaches an object?
2. In that case, what does the light model predict you will see if you replace the cardboard divider in the light box with a clear plastic divider?

## Observation

1. Put the cardboard divider in the light box. Look at the object in the box. Talk with your group about what the light is doing so that you can or cannot see the object.
2. Now replace the cardboard divider with a clear plastic divider. Look at the object again. Talk with your group about what the light is doing so that you can or cannot see the object.

## Evaluation

Why does the consensus model not help you explain how you were able to see the object through the transparency?



## Revise

The light model needs to be revised to explain that you can see an object in the light box through a clear plastic divider.

1. Draw the light model so that it explains the following:
  - How can you see an object on the opposite side of a clear divider?

- Why is it possible to see the clear divider itself?
2. How does your drawing show that it is possible to see the object through the divider?
  3. How does your drawing show that it is possible to see the divider itself?

### **Making Sense**

Earlier in the unit, you developed a model to explain how people see. In this activity, you figured out that there is a problem with that model, because it did not predict that you can see an object through a clear divider. The model had to be revised so that it could explain and predict such situations.

Models become better when they can be used to explain and predict more things. Scientists evaluate their models all the time and revise them if they do not match the evidence they gather.

## ACTIVITY 7.2 – MEASURING LIGHT TRANSMISSION

### What Will We Do?

We will compare our naked-eye observations of transmission with measurements taken by instruments.

### Prediction

Use the following table to order the objects you have collected according to how much light they transmit. The object that transmits the most light should be first on your list. The object that transmits the least light should be last on your list.

Objects we collected in order of most (1) to least (6) light transmitted as we look at them	
1	
2	
3	
4	
5	
6	

Use the following table to order the objects collected by another group. Use the same scale of 1–6 for how much light they transmit.

Objects another group collected in order of most (1) to least (6) light transmitted	
1	
2	
3	
4	
5	
6	

### Data

Next you will measure transmission with a light sensor. In the space provided, create a data table for recording measurements of how much light is transmitted by each of the six objects.

In the following space, create a data table for recording the other group's data.

Use the following table to order the objects you gathered by how much light they transmitted, most to least, according to the reading on the light sensor.

<b>Objects we collected in order of most (1) to least (6) light transmitted and measured by a light detector</b>	
1	
2	
3	
4	
5	
6	



Use the following table to order the objects gathered by the same group with which you traded before.

Objects collected by another group in order of most (1) to least (6) light transmitted and measured by a light detector	
1	.....
2	.....
3	.....
4	.....
5	.....
6	.....

### Making Sense

Look at the lists another group made for the objects you collected. Which list matches better? The one made by estimating the amount of transmitted light with your eyes, or the one made by measuring light using the light sensors?



A large, rounded rectangular box with a green border, intended for writing an answer to the question above. A small pencil icon is located in the top-left corner of the box.

What are some reasons why measurement devices were useful in this investigation?



A large, rounded rectangular box with a green border, intended for writing an answer to the question above. A small pencil icon is located in the top-left corner of the box.



## Homework 7.2 – Transmission of Light – Part 1

### What Will We Do?

We will think about how measuring and transmission are important outside of science class.

1. List five measurement devices you have used outside of school. For each one, explain why it is useful.

Measurement Device	Why Is This Device Useful?

2. Look around your house or outdoors. Find five objects that use transmission of light to do something or to make life easier.

Object	How Does This Object Use Transmission of Light?

## ACTIVITY 7.3 – REVISING THE LIGHT MODEL

### What Will We Do?

We will use the light model to predict why it is possible to see through some objects but not through others.

### Prediction

The following diagram shows light leaving a source and hitting a piece of glass. Draw what you think will happen to the light rays as they hit the glass. (Hint: Can you see through glass? Can you see a reflection of yourself in glass?)

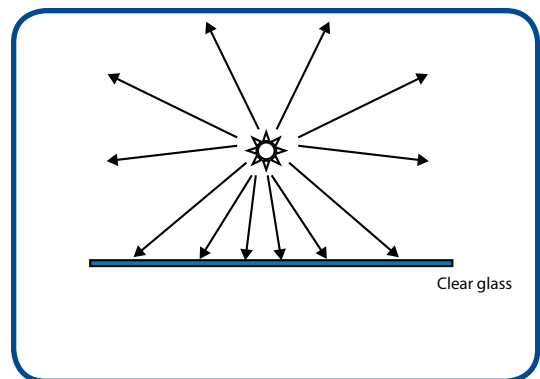

The following diagram shows light leaving a source and hitting a piece of unpolished wood. Draw what you think will happen to the light rays as they hit the wood. (Hints: Can you see through wood? Can you see your reflection on a wood surface?)

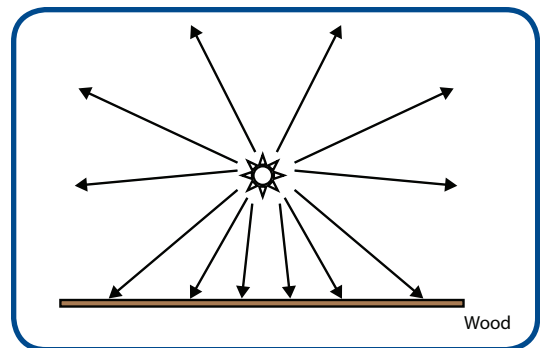

## Making Sense

In Lesson 6, you looked at a photo of paper taken with a microscope. You saw that paper is made of fibers, and you learned that light scatters off the surface of paper. Imagine that a person is looking through a sheet of paper, as shown in the the following incomplete model. Imagine that the person can barely see the light source through the paper. Complete the model by drawing arrows to show this.

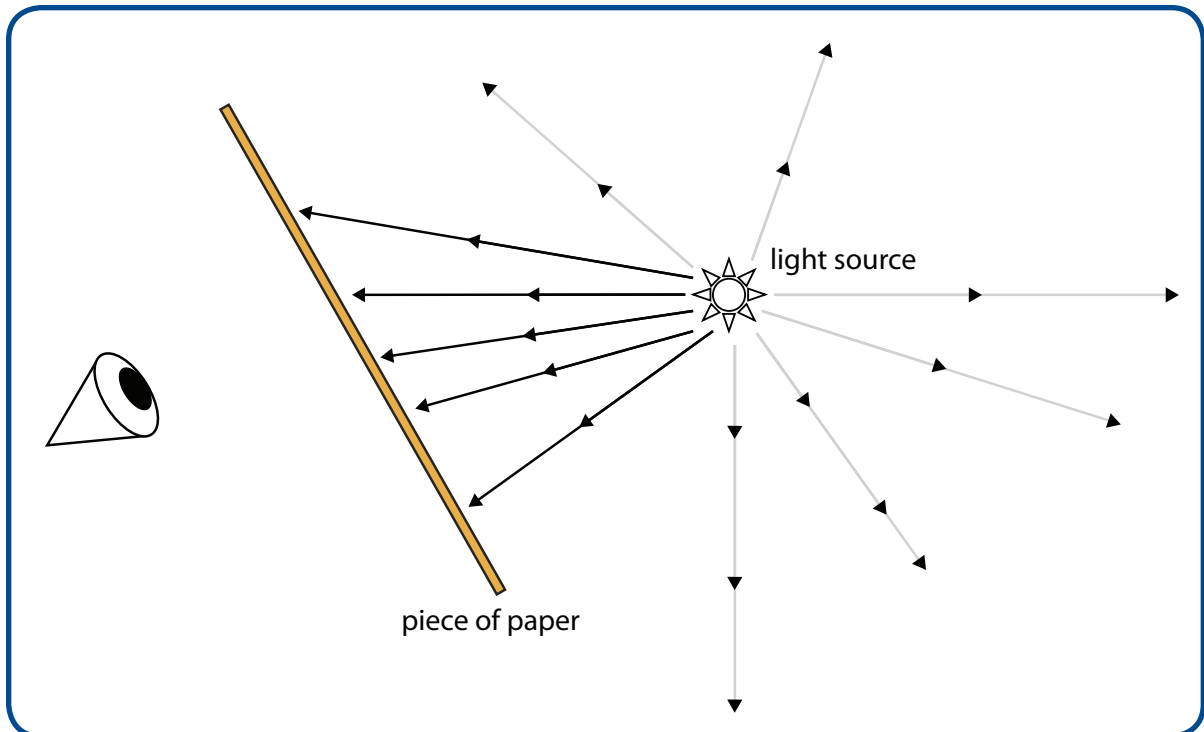



## Homework 7.3 – Transmission of Light – Part 2

### What Will We Do?

We will examine more examples of transmission and reflection of light. When we investigate, think, talk, and write about science, we understand it better.

Light from a flashlight is shown hitting two different objects below.

1. Complete each diagram, so that it shows how much light you think each object will transmit.

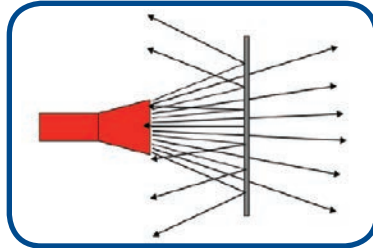

2. Make sure to show whether light that bounces off the object will be scattered or reflected.

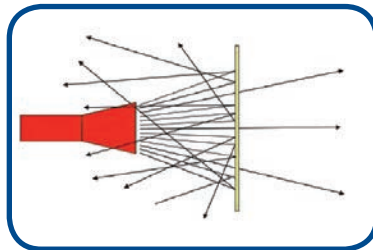

### Reflective Sunglasses

Some sunglasses have a reflective coating. The coating makes them look like a mirror, but it still allows the person to see.



### Rice Paper

Rice paper is used in places like Japan to make doors that let light through. The picture shows a door made with rice paper.

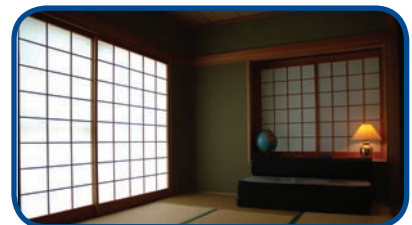

### Making Sense

After Eva cleaned the sliding glass door at her house, her friend came over and walked right into it. Why is it easier to see the glass when it is dirty than when it is clean?



## Reading 7.3 – Using Light in Optical Fibers

### Getting Ready

Have you ever seen a lamp like this one? The lamp has hundreds of thin plastic fibers coming out of it. The ends of the fibers glow with a tiny light. These tiny strands are called optical fibers. Optical fibers are used to make fun lamps, but they are also used in other ways to make your life easier. Every time you go on the Internet, you send and receive information using optical fibers. Optical fibers also make it possible for a television to get hundreds of channels. In this reading, you will learn about optical fibers and how they work. They are one of the ways that scientists create new things, because they understand light.



### How Do Optical Fibers Work?

Look around your house for a piece of clear plastic. You might find a CD case, a soda pop bottle, or plastic wrap from the kitchen. Notice that you can see through the clear plastic. Explain how it is possible to see something on the other side of the plastic, even though the plastic is blocking the path between the object and your eye.



Look carefully at the plastic surface. Explain how it is possible for it to transmit light and for you to also see your reflection.



### What Does Plastic Have to Do with Optical Fibers?

Optical fibers work because light is reflected and transmitted by materials in the fiber. Most optical fibers are made of glass surrounded by other materials. Light that travels into the core travels through it because the clear glass transmits light easily. What makes optical fibers special is what happens when the transmitted light hits the side of the clear glass core—it is reflected like it would

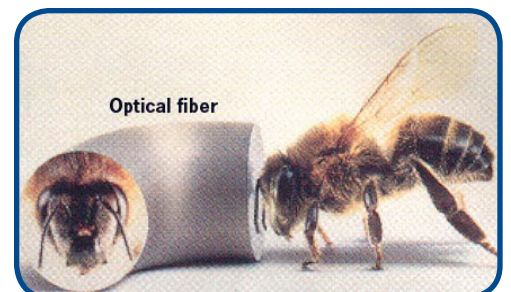

from a mirror. Because the light is reflected, it can follow along the fiber, even when the fiber is bent. This is why optical fibers are sometimes called light pipes. People can direct light down an optical fiber much like they can direct water through a water pipe. Note the picture of a bee looking into a thick piece of optical fiber. While it looks like there is another bee coming out of the optical fiber, you are really just seeing light that has been scattered from the bee, transmitted, and directed along the bent fiber.

### *How Does Our Light Model Apply to What Happens in Optical Fibers?*

In class, you created a consensus model to describe how light helps you see. In this model, you drew light as straight lines that go out in all directions from a light source. If light bounces off an object, it changes directions and then travels in a straight line again. You drew light as straight lines because when light travels through the air, it moves in a straight line. Light also moves in a straight line in an optical fiber. Light does not bend; it just seems to bend as it changes direction when it is reflected at the sides.

If you shine a flashlight in the air, the light will follow a straight path until it hits an object. If you shine a flashlight into one end of an optical fiber, the light will follow the path of the cable and come out the other end. Go back and look at the picture of the lamp at the beginning of this reading. The ends of the fibers are bright, because light from the lamp has followed the fibers and is leaving them at the other end.

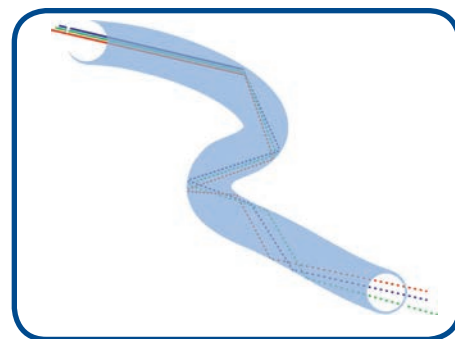

### *How Are Optical Fibers Useful?*

You may already know that computers communicate with each other using electrical wires. Computers can also communicate by shining light down optical fibers. Why would people prefer to send signals down a fiber using light instead of down a wire using electricity? One reason is that optical fibers can be much thinner than electrical wires. Both the wire bundle and a single fiber can do the same job. A single fiber can do the work of many electrical wires.



Have you ever tried to load a webpage and had to wait a long time? This happens because many computers are trying to send signals down the same wires. Trying to send many signals down the same wire is like trying to drive a lot of cars on the same road. If there are too many cars on the road, there will be a traffic jam. Because optical fibers are smaller but can carry more signals at once, they can help to prevent traffic jams that happen on the Internet. This is why some people call the Internet the *information superhighway*.

New ways of communicating are everywhere. Television has changed a lot since your parents or grandparents were young. Ask a parent, grandparent, or another older person the following questions about television:

- How many channels could they get on TV when they were your age?
- How did the TV reception compare to today?

Why do you think the situation today is different than what they described? Describe what you learned.



### *Using Optical Fibers: Surgery*

When doctors do surgery, they must be able to see inside a patient's body. Usually, they have to cut into skin. By using optical fibers, doctors can make very tiny cuts and leave scars that are almost invisible. After making a tiny cut, doctors insert a small optical fiber. They can light up the inside of the patient's body by sending light through the fiber. When the light hits something inside the body, it bounces off and enters a second optical fiber. The second cable carries the light to a camera. The camera produces a picture that the doctor can see on a television screen. Optical fibers have made surgery much safer for patients.



### *Using Optical Fibers: Lighting*

Have you ever been in a room with no windows? Many people who work in office buildings do this every day. Some scientists are working with optical fibers to change that. By putting one end of an optical fiber outside, it is possible to send sunlight to a room that has no windows. Optical fibers may someday provide sunlight for people with no windows, even if they are underground.

Optical fibers can provide people with natural sunlight for free, but what are some disadvantages to using optical fibers to light a room with sunlight?



### *Why Are Optical Fibers Important?*

Optical fibers allow people to use light for a lot of new purposes. People can send signals between computers, and they can do much safer surgeries. To send light down a cable, optical fibers rely on reflecting and transmitting light. These are two different ways that light can interact with objects and materials. In the next lesson, you will learn about a third way that light can interact with objects and materials, and you will begin to imagine new possibilities for the future.





## LESSON 8

# Absorption of Light

### ACTIVITY 8.1 – LIGHT MAKES THINGS HAPPEN

#### What Will We Do?

We will investigate another way light can interact with objects. Light can also be absorbed.

#### Procedure

1. Your teacher will show you a radiometer, which spins when light shines on it.
2. In the following table, list other objects you have seen that when light hits them, something happens.

Describe what happens when light is shined on each object.

Object	What Happens When Light Shines on the Object?

#### Making Sense

The objects on your list all absorb light and then something happens. Which objects on your list also scatter, reflect, or transmit light?



## ACTIVITY 8.2 – INVESTIGATING HEATING BY LIGHT

### What Will We Do?

We will investigate how light interacts with water. After collecting data, we will revise our model so it can explain why sunlight feels warm.

### Procedure

A bright light will be shined on two beakers of water. One beaker contains clear water, and the other contains water colored with food coloring.

1. Predict which beaker of water will get warmer: the colored water or the clear water. Explain why you think so.
2. A light sensor and a thermometer will be used to take several measurements during this investigation:
  - a. amount of reflected light
  - b. amount of transmitted light
  - c. starting water temperature
  - d. ending water temperature
3. Create a data table to record the measurements for the clear water and the colored water.

### Data

## Making Sense

1. How does the amount of light reaching the colored water compare with the amount reaching the clear water? How do you know this?
2. The following will help you use your data to understand why one beaker of water got warmer than the other.
  - a. Add the amount of reflected light to the amount of transmitted light for the clear water.

<b>Light reflected</b>	
<b>Light transmitted</b>	
<b>Total light measured by the sensor</b>	

- b. Add the amount of reflected light to the amount of transmitted light for the colored water.

<b>Light reflected</b>	
<b>Light transmitted</b>	
<b>Total light measured by the sensor</b>	

- c. How is the total amount of light that you measured (light that was reflected and transmitted) related to the amount of heating?
3. What do you think happened to the light that caused the water to heat up? If it helps you, draw (construct) two models of what happens to the light in the case of colored water and clear water.



## Reading 8.2 – Solar Power Plants

### Getting Ready

In class, you are investigating how light can be used to heat water. What are some reasons people would want hot water or steam?



Did you know that steam can also be used to generate electricity? In this reading, you will learn more about how light makes things happen. For example, light can be used to generate steam, which can generate electricity.

### Using Steam to Do Things

Almost all of the electricity that people use to light lamps, to keep food cold in refrigerators, or to watch television is generated by a machine called a steam turbine. You do not have a steam turbine in your home. Somewhere, at some power plant, a steam turbine generates electricity and sends it through wires.

A steam turbine is a machine with giant fan blades inside. When the fan blades turn, the machine uses the turning motion to generate electricity. The trick is to figure out a way to make the fan blades turn.

You can think of the blades inside a steam turbine like a giant pinwheel. When you blow on a pinwheel, the air you breathe out hits the blades of the pinwheel and move them. Now, imagine that you could hold the pinwheel above a pot of boiling water. The steam would also make the pinwheel turn, just like with you blowing on it.

Making a pinwheel turn by holding it above boiling water is the same idea as using steam to turn the fan blades inside a steam turbine. Long ago, someone needed to figure out how to heat water enough so that it turns to steam. Then the steam could operate the turbine and generate electricity for people's homes.

Most of the electricity generated in the United States is produced by coal power plants, which burn coal to heat water until it becomes steam.

### *Solar Power*

In class, you are investigating how light from a light bulb can be used to heat water in a beaker. Some power plants, called solar power towers, use light from the sun to heat water until it becomes steam. A solar power tower uses thousands of mirrors to reflect light from the sun to a tower that holds water. Look at the photo to see how this looks.



When light reflected by the mirrors hits the tower, the water inside is heated. If the water is heated enough, it becomes steam. The steam is transported through pipes to a steam turbine, which produces electricity.

One drawback of a solar power tower is that it can only heat water during the day. Once the steam cools down and becomes water again, it cannot turn the steam turbines. People still need electricity at night or when the sun is blocked by clouds. To produce electricity at these times, some solar power towers heat a different liquid instead of heating water. Once the fluid is heated, it can be transported through pipes to come in contact with a container of water. There, it heats the water to make steam. It takes the special fluid a long time to cool down, so it can remain very hot throughout the night. Because the fluid stays hot, it can heat water to create steam even when the sun is not shining.

### *Solar Chimneys*

Another way to use light from the sun to generate electricity does not involve heating water at all. In a solar chimney, light from the sun heats the air underneath a large glass roof. The hot air rises and is forced through a giant chimney. As the heated air rises, it turns fan blades to generate electricity. The sun can only heat air during the day, so solar chimneys have pipes filled with liquid that remains hot at night. That means the solar chimney works even when the sun is not shining.

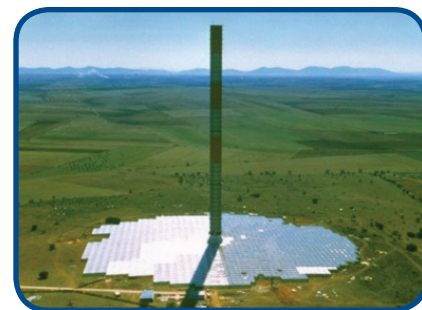

Light from the sun can heat an object when it hits it. This is why your skin feels warm in the sunlight. In the investigation you are doing in class, you will determine how light heats things and why some materials get hot faster than others.

The light your teacher uses to heat beakers of water is called a flood lamp. Notice that a flood lamp has silver sides designed to reflect light. In what way does the flood lamp work to heat light faster than a regular light bulb?



You have learned that light can be scattered (or reflected if the object is smooth) or transmitted when it reaches an object. In class, you used light to heat two beakers of water. If all the light that reached the beakers was scattered or reflected, how hot would the water be?



How hot would the water be if all the light reaching the two beakers had been transmitted?







## ACTIVITY 8.3 – KEEPING TRACK OF LIGHT

### What Will We Do?

We will revise our light model to account for all three ways that light can interact with objects and materials. Objects can reflect or scatter, transmit, and absorb light.

### Observations

During the last activity, you investigated what happened as a beaker of clear water and a beaker of colored water were heated using light from a flood lamp. Based on what you saw in that experiment, answer the following questions.

1. Which beaker transmitted more light?
2. Which beaker reflected more light?
3. Which beaker absorbed more light?
4. What evidence showed which beaker absorbed more light?

### Making Sense

These diagrams show two incomplete models in which light is leaving a flood lamp and traveling toward a beaker of water. Complete the following models by drawing additional light rays that can be used to explain your observations. Make sure of the following:

- a. Your models show the same amount of light reaching both beakers.
- b. One model shows different amounts of light being reflected, transmitted, and absorbed than the other.

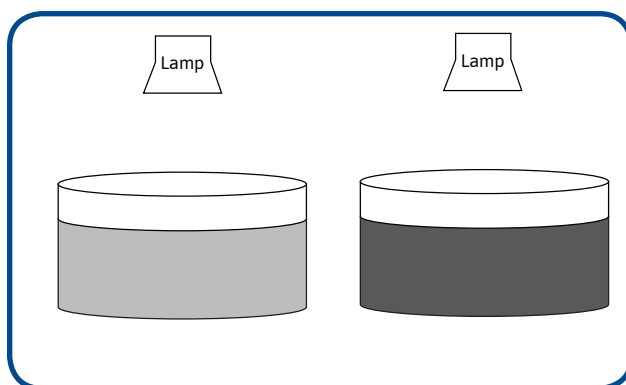

## ACTIVITY 8.4 – REVISITING PHENOMENA CAUSED BY LIGHT

### What Will We Do?

We will examine how devices use reflection or scattering, transmission, and absorption to make things happen.

### Procedure

1. Look at the object your teacher shows you.
2. Does the object reflect/scatter a lot of light? How do you know?
3. Does the object transmit a lot of light? How do you know?
4. Does the object absorb a lot of light? How do you know?

### Making Sense

1. In several activities you saw that light was scattered, transmitted, absorbed, or some combination of these. In the activity with the clear and colored water, you saw that the more light that was absorbed, the less that was scattered and transmitted. Is this relationship true for the object your teacher just showed you? Make a general rule about the way the amounts of light reflected or scattered, transmitted, and absorbed by any object are related to each other.
2. If you designed a device that uses light to make something happen, like heating something, making something move, or generating electricity, would you want most of the light that reaches the device to be reflected, transmitted, or absorbed? Why?



## Homework 8.4 – Absorption of Light

### Purpose

Apply what we have learned about light to situations that happen outside of science class.

1. Two potatoes are left in the sunshine for an hour. One potato is covered with aluminum foil. The other potato has nothing covering it. After the end of the hour, which potato will be warmer? Explain.
2. A solar cell uses light from the sun to run electronic devices like calculators. Solar cells have a coating that reflects as little light as possible. Why would this be important?
3. Light from the same flashlight is shined on several objects. A light detector measures the light after it hits each object. Use the following data to determine which object absorbed the most light.

Object	Light Scattered	Light Transmitted
T-shirt	131lux	14lux
Cardboard	180lux	2lux
Ice cube	450lux	100lux
Brick	157lux	0lux

4. Which object absorbed the most light? Explain.



## Reading 8.4 – Solar Energy

### Getting Ready

Have you ever gone into a room where the sun was shining brightly through the windows? If so, how did the temperature in this room compare to the temperature of other rooms?



In class, you learned that light can interact with objects in three ways. Light can be reflected (or scattered), transmitted, and absorbed. When light hits an object, one, or two, or all of these can happen at the same time. When light from the sun reaches a clear window, some of the light is reflected off of the smooth glass. Some of the light is absorbed by the glass, but most of the light is transmitted. Most of the light continues to travel until it reaches an object in the room, like the floor, walls, or furniture. These objects then scatter, transmit, and absorb the light that reaches them. The light absorbed by the objects causes them to heat up. These heated objects can then heat other stuff in the room, such as the air, the ceiling, and even you.

Today, you will read about many ways that people use sunlight, because they understand that light can make things happen.

### How Do People Use Reflection?

Have you ever seen a building that looks as if it were made out of mirrors? These buildings are made using reflective glass. How would replacing clear windows with reflective glass affect the temperature inside the building? Explain your ideas.



In class, you saw that light can cause many types of changes in objects besides heating them. Light makes plants grow, radiometers spin, and light-sensitive paper change color. You learned that in order for these changes to occur, light reaching the object must be absorbed. Light carries energy as it travels, so when light is absorbed by an object, energy is transferred from the light to the object that it hits. It is the transfer of energy that enables objects to heat up, spin, grow, or change color. The energy carried by the light from the sun is called light energy or solar energy. Solar energy can be used in many ways.

### Solar Water Heaters

Solar energy is widely available in California because it is very sunny. People who live in California have been using solar energy from the sun for a long time. Some people use solar energy carried by light from the sun to heat their water. Solar water heaters are often placed on roofs to absorb sunlight directly. People in southern California have been using solar water heaters for over a hundred years. By using solar energy, people do not need to pay for the gas or electricity that power most water heaters.



Most solar water heaters have three parts: a hot water storage tank, a solar collector that absorbs light from the sun, and a backup gas or electric heater that can heat the water in case of a cloudy day. Look at the picture of the solar water heater. It is designed to absorb as much light as possible and reflect as little light as possible.

Think of the activity you did in class when you used a light bulb to heat a beaker of clear water and a beaker of colored water. Use what you learned from that activity to help you explain why it is best for solar collectors to be black.

Do you think using solar water heaters would be a good idea where you live? Why?



### How Does Solar Energy Make Electronics Work?

Heating water is not the only way to use solar energy. Have you ever seen a sign that looks like the one in the photograph? To get people's attention, lights flash above and below the sign. These lights need electricity to operate, but they do not need to be plugged in. The dark panel on top of the sign is called a solar cell. It is similar to the solar collectors you just read about.



A solar cell produces electricity by using light energy from the sun. Solar cells are useful for things that need electricity but are not near an electrical outlet. States like New Mexico and Arizona use a lot of solar cells because they have a lot of sunlight, and many desert areas are far from electricity.

Solar cells are also useful to move things. For example, scientists can build cars that never need gasoline. These cars have solar cells, so they move using light energy from the sun.

### *Solar Panel Powers Calculator*

Some calculators are designed to operate using a small solar cell. Like the solar collectors on solar water heaters, solar cells are designed to absorb a lot of light and to reflect very little. Explain why a good solar cell absorbs a lot of light and reflects a small amount of light.



Some miniature cars can run using small solar cells, but the solar cells needed to run a real car must be very large. Using what you know about solar energy, explain why a real car needs a bigger solar cell than a miniature car.



Solar energy can be used to heat water, generate electricity, move things, or even make living things grow. Since it is plentiful, and it does not create pollution, solar energy is an excellent energy resource. You may want to learn more about solar energy on the Internet.



## LESSON 9

# What Is the Opposite of White Light?

### ACTIVITY 9.1 – MIXING COLORS OF LIGHT WITH PROJECTORS

#### What Will We Do?

We will explore light and color and different colors of light in order to answer the Driving Question.

#### Procedure

Today, you will explore light and color using projectors or flashlights. It is important to make careful observations during each step of the investigation.

1. Explain why the screen looks brighter when a projector (or flashlight) is shining on it than when it is turned off. It is not enough to say that more light is shining on it. Use the light model to explain the amount of light reaching the screen and your eyes. (You may also draw the model if that would be helpful.)
2. What do you see on the screen when a red filter is placed on the flashlight or the projector projects red light?
3. Predict what color of light you will see on the screen when your teacher aims three projectors or three flashlights (red, green, and blue) so that their squares or circles are overlapping.



## **Making Sense**

1. Explain why you saw the color you did when all three colors of light were overlapping.
  
2. When you mix different colors of light, the new color you see is brighter than the original colors you mixed. Explain why this happens.

## ACTIVITY 9.2 – MIXING COLORS OF LIGHT ON COMPUTERS

### What Will We Do?

We will use technology to investigate how much red, green, and blue light should be mixed to create white, black, and shades of gray.

### Procedure

1. Go to the following website: [http://www.exploratorium.edu/exhibits/mix\\_n\\_match/](http://www.exploratorium.edu/exhibits/mix_n_match/) (or do a web search for “Exploratorium mix n match”. Note you will need to be able to run Shockwave on your computer, and it will not run on an iPad)
  - a. Click on Mix-n-Match.
  - b. Read the instructions on the website about how to investigate making different colors by combining red, green, and blue light.
  - c. Make sure each student in your group has at least one opportunity to operate the computer.
  - d. Students who are not operating the mouse should make suggestions about how to get the desired color.
2. Investigate white light.
  - a. How much red, green, and blue light do you think need to be mixed to create white light? Record your predictions before you try it.
  - b. Manipulate the computer until you succeed in making white light.
  - c. Record your results.
  - d. Why do you think this particular combination makes white light? Discuss this in your group.
3. Investigate black light.
  - a. How much red, green, and blue light do you think need to be mixed to create black light? Record your prediction before you try it.

- b. Manipulate the computer until you succeed in making black light.
- c. Record your results.
- d. Why do you think this particular combination makes black? Discuss this in your group.

4. Investigating gray light.

- a. How much red, green, and blue light do you think need to be mixed to obtain gray light? Record your prediction before you try it.
- b. Manipulate the computer until you succeed in making light gray light and dark gray light.
- c. How much red, green, and blue light do you think need to be mixed to obtain light gray light? How much is needed to obtain dark gray light?
- d. Why do you think these particular combinations made these shades of gray? Discuss this in your group.

## Making Sense

Computers can only emit red, green, and blue light. Yet, your computer screen shows a picture with green grass, a blue sky, a yellow sun, and a brown house. How do you think the screen makes these different colors?

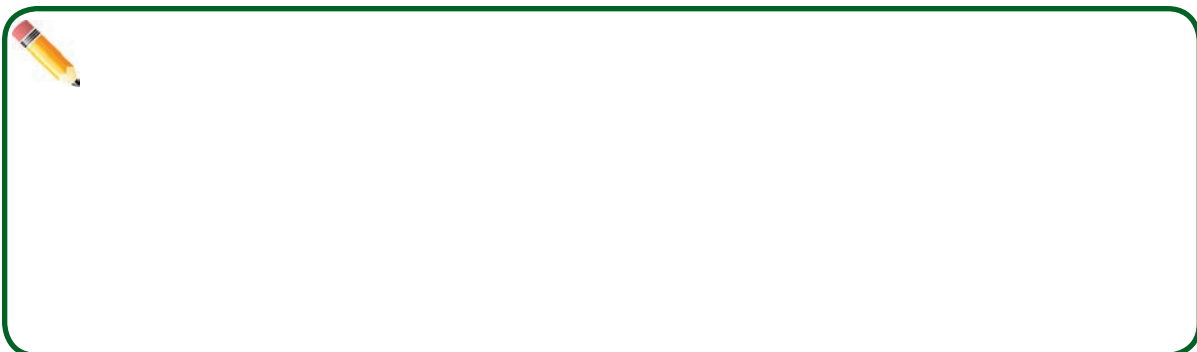

## ACTIVITY 9.3 – HOW COLOR SENSORS WORK

### What Will We Do?

We will learn how the eye and digital cameras detect different colors of light. We will also learn why mixtures of colors of light appear to our eyes to be new colors.

### Procedure

1. Look at the images that describe the structure of two things: the human eye and a digital camera. Use the space provided to take notes.

A digital camera is like the eye—at its back is a device called a CCD that has three different types of cells that detect red, green, and blue light.

2. What are the two types of cells in the retina of an eye?
3. Each type of cone cell detects a different color of light. What are the three colors of light the cone cells in the retina are sensitive to?
4. When you are in a dark, but not completely dark room, it is impossible to detect the colors of objects in the room. Everything seems to be different shades of gray. Explain why you can only see shades of gray.
5. How is the design of the CCD of a digital camera similar to the retina of the human eye?

6. You have learned that the eye is a light sensor. Answer these questions about the eye:
- a. How do light rays enter the eye while seeing?
  
  - b. Why does the pupil open wide in the dark and narrow down in bright light?
  
  - c. Why does the pupil look black?

### **Making Sense**

When a mixture of red and green light enters your eyes, you perceive the mixture as yellow light. Explain why your eye perceives this mixture of red and green light as yellow.





## Reading 9.3 – Making Color Photographs

### Getting Ready

Have you ever seen a black and white movie? Did you ever wonder why old movies were always in black and white instead of in color? After all, everything in the movie was actually colored.

Today, you will read about how cameras make pictures in color. What you learned in class about color mixing can help you think about movies and about photographs.

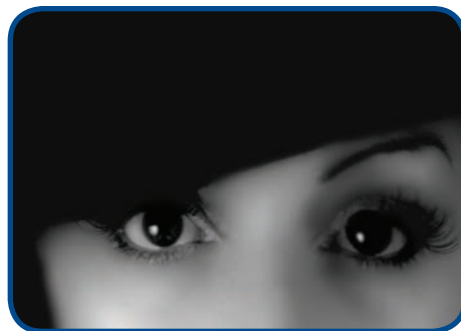

### What Happens When I Mix Colors of Light?

In class, you learned how the eye detects colors. You also learned that two things happen when you mixed colors of light. First, when you mixed colors, you ended up with a new color. Using two sources, you mixed red light with green light and got yellow. When you added blue light from a third source, you got white.

Second, when you mixed colors from two sources, the new color was brighter. The color in the area lit by all three sources was the brightest of all the colors. You might also have used a computer simulation on the Internet to see that whenever two colors of light are mixed, the new color is brighter than the old ones.

This happens because as you increased the amount of light, more light was available to reach your eyes. On the Internet, if you see a simulation about “mixing light” or “mixing colors of light,” you will see that when you mix maximum amounts of red, green, and blue light, you see white. On the other hand, when you mix no red, green, or blue light, you see black. These activities help you learn that white light is the brightest of all colors, and it is a mixture of many colors. When you see black, it means that there is no light present.

1. Why do you think a shadow is black?

### How Do People See Different Colors?

In the previous activity, you learned how people see different colors. The retina, in the back of the eye, contains cells that are sensitive to light. Two kinds of cells are in the retina: cone-shaped cells and rod-shaped cells. The rod-shaped cells tell you how bright or how dark something is. The three different kinds of cone-shaped cells are each sensitive to a different color of light. Some are sensitive to red light, some to green light, and some to blue

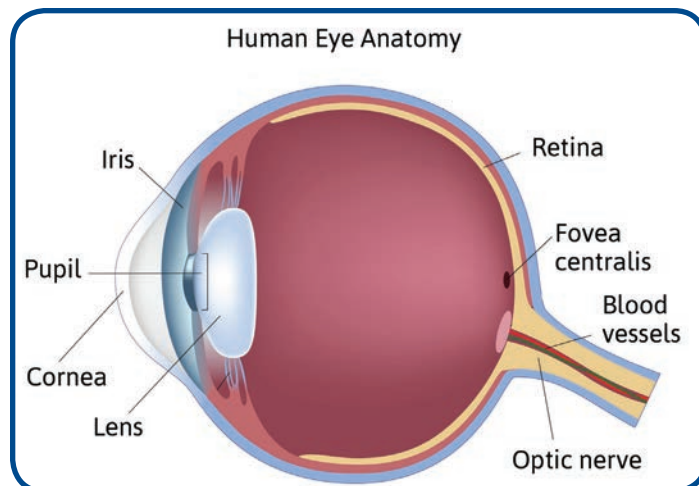

light. All these cells send signals to your brain. Your brain processes these signals as images. In Lesson 9, you learned about digital cameras and found out that they work much like your eyes—they detect the light coming into them. Some cameras use film instead. Cameras with film also detect the light coming into the camera and to the film to record it. You may have taken pictures on a camera that uses film. Once you have used up your film, you have to take it to a store to be developed. Only then can you see the pictures that you took.

### *How Does Film in a Camera Record Different Colors of Light?*

Just like your eyes, a camera has a hole that lets light inside. In your eye, this hole is your pupil. In a camera, this hole is the shutter. When you press the button to take a picture, you open the shutter. In a split second, light enters the camera and travels through it. The light reaches the back of the camera where the CCD is located. In a camera that uses film, this is where the film is located. The film absorbs light and causes it to change color. Red light causes the film to change in a different way than blue light. In black and white film, all colors of light will cause the film to change in the same way. Instead of producing areas with different colors, black and white film only produces areas that are lighter or darker.

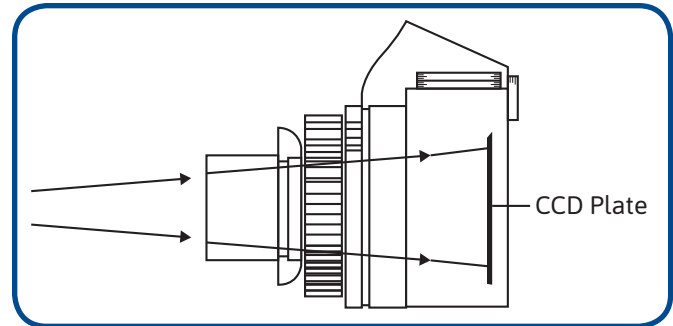

Color film is made of three layers. These layers of film are like the cone cells in the retina of an eye. Some layers sense red light, others green light, and others blue light. The difference is that in the retina, the different cone cells are located side by side, and in film the different layers are one under the other. If color film is hit by red light, the layer that is sensitive to red light does not become red—it becomes light blue. Green light makes the layer sensitive to green light become light purple. Blue light makes the layer sensitive to blue light become yellow. So if you look at film after it has been exposed to light, what you will see will look very different from the object that you took a picture of. It will have the same shape, but all the colors will be wrong. This photo shows what film would look like if you took a photo of a castle. It is interesting to look at the negatives from film that has been developed to see the difference between the negatives and the photos!



After photos have been taken, film needs to be protected so it will not get exposed to any more light. Film can still absorb more light. If more light were to strike the film, it would record this light as well as the light that hit it while taking the pictures. This would mess up the first picture it recorded.

The film is rolled and placed into a canister that does not let in any more light. The person who develops the film opens the canister in complete darkness and puts the film into a liquid that makes the film no longer sensitive to light. The film can then be taken out into the open

without any worry of messing it up. The store then uses the film to print photos. The machine that prints pictures on film changes the colors on the film back to the original colors, so the photos look like the original objects.

2. Why do you think there is a need for three layers in a film?
3. Why do you think the layers in the film need to be transparent to all colors other than the one it absorbs?

### *How Does a Television Show Colors?*

Most televisions have “guns” near the back that send tiny particles called electrons toward the screen. Magnets inside the television can push or pull the electrons up, down, left, or right, so that they can hit the screen anywhere. The inside surface of a television screen is coated with very small dots. When an electron hits a dot, it makes a weak flash of light. There are three different kinds of dots, and each one generates a different color of light. By controlling which dots are hit by electrons, someone can control which colors of light are made by the screen at each point on the screen. As you learned in Lesson 9, your eyes perceive different mixtures of red, green, and blue light as new colors. Since the dots on the screen making the light are so small, you cannot tell them apart. When two dots next to each other light up at the same time, you see only one flash of light. The color of that light will depend upon the colors of light made by the dots.

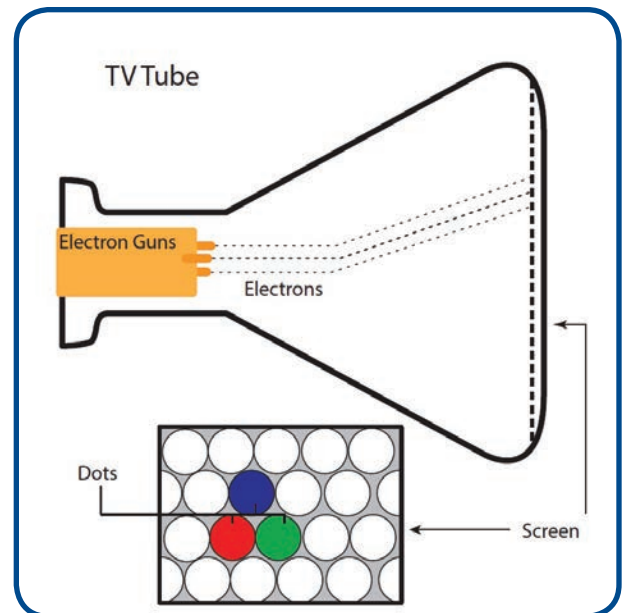

You have learned how camera film and televisions combine only three colors of light to make all the colors that your eye can see. For example, you know that red and green light can mix to make yellow light. Think of it next time you see something yellow like a flower. Are you actually seeing yellow light, or is it a mixture of red and green light that looks yellow to your eyes? In the next lesson, you will learn how you can tell whether you are seeing a pure color or a mixture of different colors of light.





## LESSON 10

# How Do Objects Change the Color of Light?

### ACTIVITY 10.1 – ANALYZING COLOR COMPOSITION

#### What Will We Do?

We will learn how to analyze light to determine out of which other colors of light it is composed.

#### Procedure

1. Your teacher will project a white line on the screen. Explain why the line appears to be white.
2. When your teacher covers the projector with a piece of C-Spectra, two colorful images are created. Each image contains all the colors of the rainbow. Make a list of the colors that you see.
3. Explain how you think different colored objects that do not transmit light, like a ball or a table, color the light that they scatter or reflect. Draw a model if it helps you.
4. Using a piece of C-Spectra, one person in your group should look at the colored line on the sheet of black paper that your teacher tapes to the board. This person should check in the table the colors that they can see. Then, when the teacher tapes a different sheet to the board, a different student should analyze the new line. Every person in your group should have the opportunity to analyze at least one line.

## Colors of Light

	Red	Orange	Yellow	Green	Blue	Violet
Red Line						
Orange Line						
Yellow Line						
Green Line						
Blue Line						
Violet Line						

5. Explain why you think the different colored lines scatter different colors of light.
  
6. Why do you think the colored lines were printed on black paper rather than on white paper?

## Making Sense

1. What color do you think you would have seen if the red stripe had been illuminated by red light?  
Explain your ideas.
  
2. What color do you think you would have seen if the red stripe had been illuminated by green light?  
Explain your ideas.



## Reading 10.1 – Rainbows

### Getting Ready

Have you ever wondered why rainbows appear? You have probably noticed that rainbows have something to do with the weather. You have probably thought about the fact that the word *rainbow* has *rain* in it, and that is when you see rainbows. However, you do not see a rainbow every time it rains. This reading is about what makes rainbows appear in the sky.



Think of a time when you have seen a rainbow. Try to remember what the weather was like at the time. These three questions might help you:

- Was it still raining or had the rain stopped?
- Was the whole sky cloudy?
- Was it during the day or night?

### You Can Make Your Own Rainbow

Before reading, here is an activity you can do to create your own rainbow. You need to do this on a sunny day. First, find a window where the sun is shining in. Second, pull a table close to the window. Third, place a full glass of water on the edge of the table where the sun is shining the brightest. Look at the following diagram to see how to set up your experiment. Once you place the glass on the table, look at the floor near the glass. You should see a rainbow on the floor.



If it is not a sunny day, you can still try to make your own rainbow. Make a room as dark as possible and set up a full glass of water on the edge of a table. Instead of sunlight, you need a flashlight. Turn on the flashlight and point it at the glass, as if the flashlight were the sun. Keep the flashlight pointed at the glass, but move the flashlight a little at a time until you see a rainbow on the floor or on the wall.

In this lesson, you will learn how drops of water and sunlight work together to form rainbows.

In Lesson 9, you learned that white light is a mixture of all the different colors of light that you can see. Red, orange, yellow, green, blue, indigo, and violet (ROYGBIV) can all be found in white light. However, when you see white light, you do not usually see those colors. In order to be able to see all the colors that make up white light, you would have to break white light apart into its color components. That is what you did in Lesson 10, using C-Spectra.

### Using a Prism

A prism is another way to break white light into its color components. A prism is a triangular piece of transparent glass or plastic. A beam of white light shining on one side of the prism will come out on the other side broken up into its color components. This figure shows how white light entering the prism comes out in the form of a rainbow.

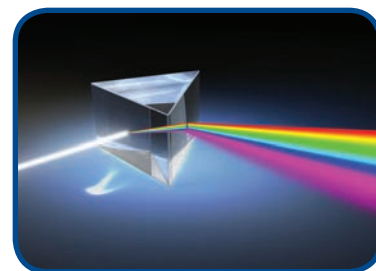

Now you know that a prism separates white light into colors and you know that the colors look like a rainbow. You still do not know how the rainbow is formed. When light enters a prism, the prism causes the light to bend very slightly or to change directions just a little bit. This bending is called refraction. Not all light gets bent in the same way. Some colors of light get bent more than others. The color of light that gets bent the most is blue, while the color of light that gets bent the least is red. Look again at the figure of light being refracted by a prism. Can you see that blue gets bent more than red? Because the different colors of light bend differently, they come out of the prism at different places and move out of it in different directions. Because they move in different directions, they spread away from each other. That is why you can see them separately—the colors are no longer mixed together. What you see is an area in which the color of light changes gradually from one to another. It looks just like a rainbow.

### How Are Real Rainbows Formed?

In a real rainbow, raindrops in the air act like very small prisms. Light enters the raindrops and gets bent by them. Each color of light is bent slightly differently. Some colors get bent a bit more; others get bent a bit less. However, unlike the prism, where the light comes in one side and leaves on another, the light entering a raindrop is reflected back at the far side of the raindrop. Look the drawing. The light returns to the same side of the raindrop it entered from, and then it exits. The light that leaves the raindrop moves in many different directions, and each color moves in a predictable direction. Refraction breaks the light entering the raindrop into color components, just like in the prism. The refraction of the light by the raindrops causes the colors to spread out to create a semicircle of color in the sky, or a rainbow.

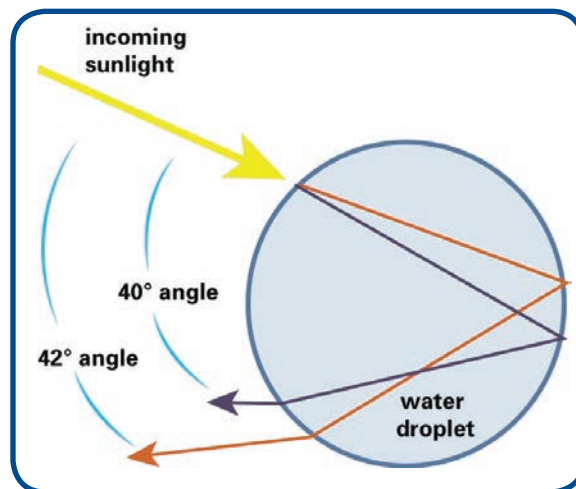

Have you noticed that the sun is always behind you when you look at a rainbow? Think about the model of light that you developed in class to help you explain why the sun must be behind you for you to see a rainbow.



### *A Special Phenomenon: Double Rainbows*

Perhaps you have seen a double rainbow like in this photo. The brighter rainbow is called the primary rainbow. The fainter rainbow is called the secondary rainbow. The secondary rainbow is made when light is reflected twice inside the raindrop. Because of the double reflection, the light leaves the raindrop at a different angle, so you see the secondary rainbow higher up. If you look closely at the picture, you will also notice that the colors of the secondary rainbow are in the opposite order of the colors in the primary rainbow. The drops of rain have to be just the right size to create two reflections. This does not happen very often, so double rainbows are a rare sight to see.



How could you explain how rainbows are formed to someone who is not in your science class? For example, how could you explain rainbows to someone at home? Or how could you explain rainbows to someone younger than you? Fill in the blank with your audience. Then explain how rainbows are formed in a way that person would understand. You might find it helpful to draw a model to explain.

## ACTIVITY 10.2 – REVISITING THE CONSENSUS MODEL





## Reading 10.2 – Lunar and Solar Eclipses

### Getting Ready

Every day the sun appears to rise in the east, go across the sky, and then set in the west. Every month the moon goes through its phases from new moon to full moon and back again. It all seems so ordered until something unexpected happens. One night the moon rises full and beautiful, but then, within a few minutes, it starts to change; it gets darker and darker, until it disappears. Then it turns red. A lunar eclipse occurs.



Our ancestors were intimidated by the sight of a lunar eclipse. They could not understand what was happening—they feared the end of the world was coming. They prayed and begged for the moon to return. Today, thanks to advances in scientific knowledge, we know what causes a lunar eclipse and we can enjoy its beauty, knowing it is a natural phenomenon, which does not cause any harm. In this reading, you will learn about lunar eclipses: why, when, and how they happen.

### Earth's Shadow

A lunar eclipse takes place when there is a full moon. You learned before that a full moon exists when Earth is between the sun and the moon. If you look closely again at the model showing the phase of a full moon, you will notice something that does not make sense. If the sun, the earth, and the moon are all aligned and the moon is exactly behind Earth, how come the moon gets lit by the sun? Shadows are actually dark areas caused by an object blocking light. Earth is an object that blocks the sun's light; therefore there is a shadowed area behind Earth. Why does the earth not always block the sun's light from reaching the moon? Is the moon not in Earth's shadow?

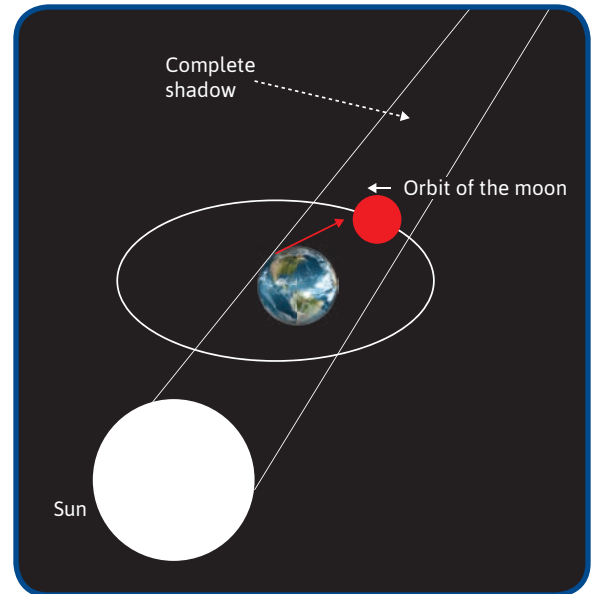

The truth is that every once in a while Earth does block the sun's light from reaching the moon, and this is what causes a lunar eclipse. How often do you think a lunar eclipse occurs? Explain.



Lunar eclipses can only happen when the moon is full and it passes behind Earth and into its shadow. If we have a full moon once every month, then we should also have a lunar eclipse once every month. This thought makes sense if you think of Earth's orbit and the moon's



orbits as being in the same plane. However, the moon's orbit is inclined about five degrees to Earth's orbit. Look at this image carefully.



That means that most of the time, during full moon, the moon passes above or below Earth's shadow and misses it entirely. No eclipse takes place. Only once or twice a year, on average, does the moon pass through some portion of Earth's shadow, causing an eclipse to occur. Upcoming lunar eclipses visible from the United States include April 15, 2014, and October 8, 2014.

Imagine you are an astronaut standing on the moon during a total lunar eclipse and watching Earth. What would you see?



A rounded rectangular box with a green border, containing a small pencil icon in the top left corner, intended for a student's answer.

If during a full moon, the sun, the earth, and the moon are all one behind the other, how come Earth does not block the sun's light from reaching the moon?



A rounded rectangular box with a green border, containing a small pencil icon in the top left corner, intended for a student's answer.

### Types of Eclipses

When the moon is in Earth's shadow, no light from the sun reaches it, and thus, even though it is in the position of a full moon, it is not illuminated and cannot be seen. Because the moon is in constant motion around Earth, it gradually enters the shadowed area—slowly disappearing until it cannot be seen at all. Then as it keeps moving, it gradually leaves the shadowed area, entering the area where sunlight can reach it again—slowly reappearing. These changes—from brightness to darkness and back again into brightness—can take up to four hours.

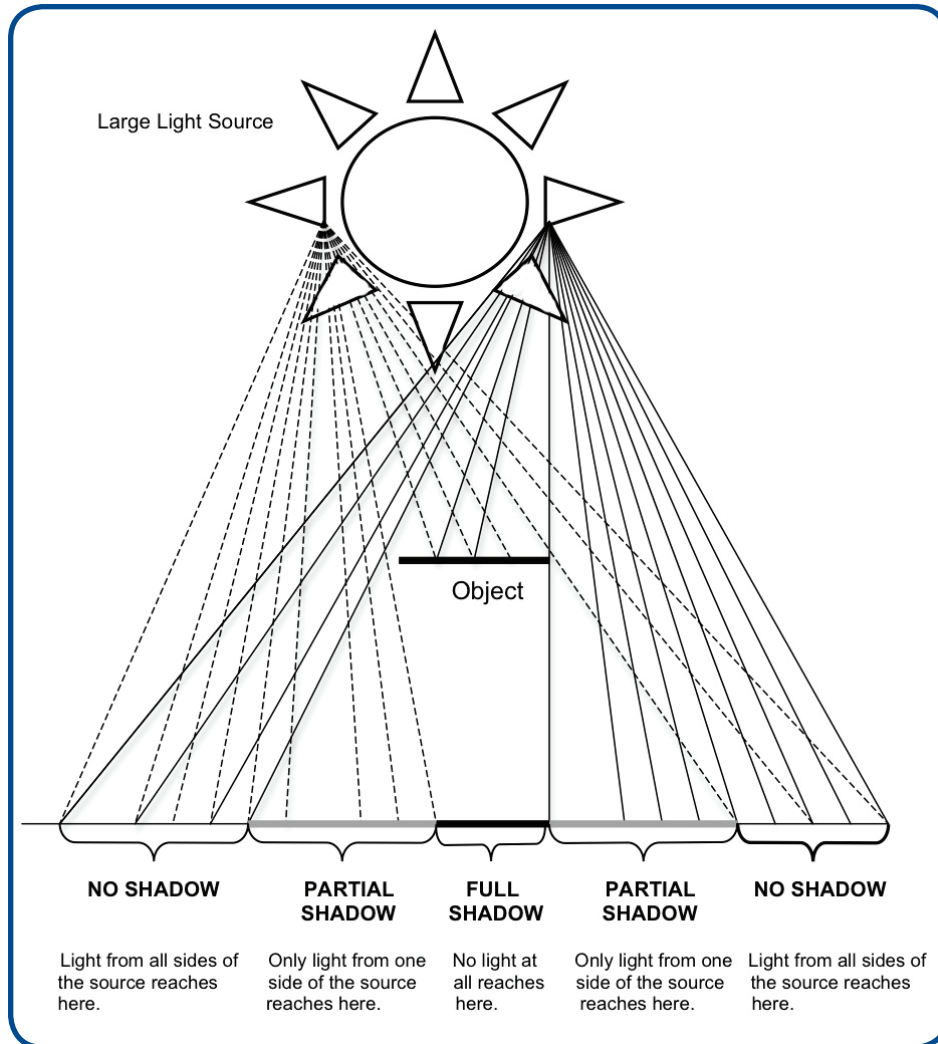

Since the sun is a large light source, it creates shadows that have fully dark areas and partially dark areas. For this reason, the shadow of Earth is actually composed of two areas. Look at the model. The outer parts of the shadow are the partial shadow—areas where Earth blocks part but not all of the sun’s rays. In contrast, the inner part of the shadow is a complete shadow where Earth blocks all direct sunlight.

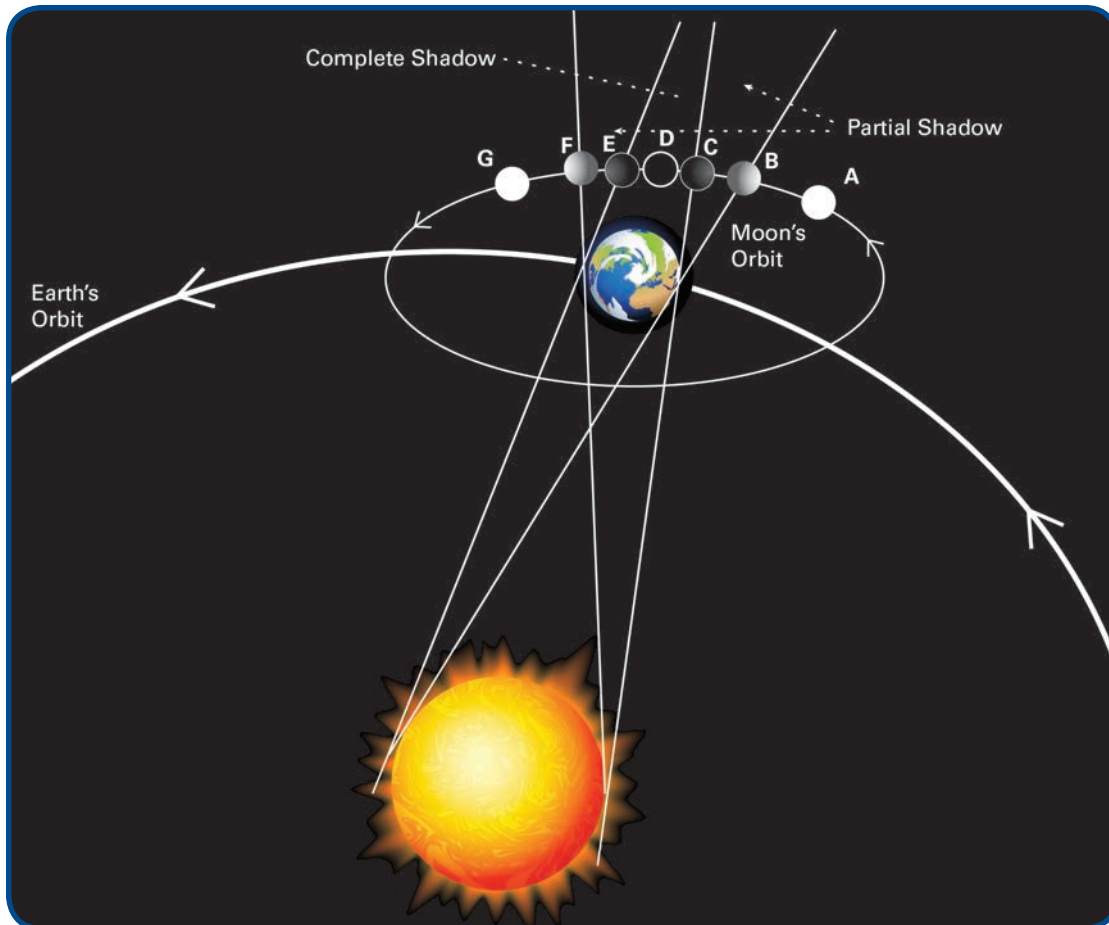

Look at the model. In which positions is the moon (A, B, C, D, E, F, or G) fully shadowed? In which position or positions is it partially shadowed? Explain.



A green rounded rectangular box containing a pencil icon in the top left corner, intended for a student's written response.

There are three types of lunar eclipse:

1. When the entire moon is in the fully shadowed area, it is fully darkened. This is called a total eclipse.
2. When only part of the moon is in the fully shadowed area, a partial lunar eclipse occurs—part of the moon is dark and the other part is partially illuminated.

3. When the moon is completely in the partially shadowed area, it is still somewhat lighted. It is difficult to notice any change with the naked eye. We need professional telescopes to observe the changes in this kind of eclipse.

Following are photos of the moon in different types of eclipses. Please write beneath each one whether it is a total eclipse, a partial eclipse, or no eclipse. Also write which position of the moon in the previous model (A, B, C, D, E, F, or G) fits each photo.



#### *Why Does the Moon Turn Red during a Total Lunar Eclipse?*

A very special feature of the total lunar eclipse is that after the moon has gone dark, it turns red. (You might want to watch an eclipse video and pay special attention to that.) The reddish color is a result of indirect lighting of the moon.

While the moon is completely within Earth's shadow, indirect sunlight still manages to reach and light it. This sunlight passes through the Earth's atmosphere. Then, it often changes direction by bouncing off the gas molecules in the air. Some of this light reaches the moon. The Earth's atmosphere acts like a filter, absorbing many colors. The remaining light is colored reddish-orange. It is much dimmer than original white sunlight. This light reaches the moon and makes it appear red. The exact color and brightness of the light reaching the moon during an eclipse depends on the how much dust is in Earth's atmosphere. After a volcanic eruption, for example, a total eclipse is very dark because there is a lot of volcanic ash in Earth's atmosphere. During the total lunar eclipse of December 1992, the moon was nearly invisible because of dust from a volcano that erupted in the Philippines.



In this reading, you learned what causes a lunar eclipse and what kinds of eclipses there are. You saw that even an amazing event, such as a lunar eclipse, can be explained by a few scientific ideas you already know. This is an example of the power of science. A small number of ideas can explain a large variety of phenomena!



### Reading 10.3 – Diffraction

A diffraction grating is a series of equally spaced, microscopic, parallel dark lines with a transparent area between them, something like what's shown in Figure 1, only much, much smaller.

When light reaches a diffraction grating, it is absorbed at the dark lines and transmitted at the transparent areas. Thus, while there was a continuous area of light before the diffraction grating, after it there are thousands of independent microscopic sources of light. From these microscopic sources, light spreads out forward in all directions. See Figure 2. Scientists say that the light has been diffracted.

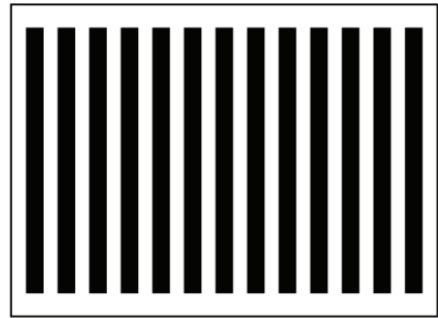

Figure 1: Magnified View of a Diffraction Grating

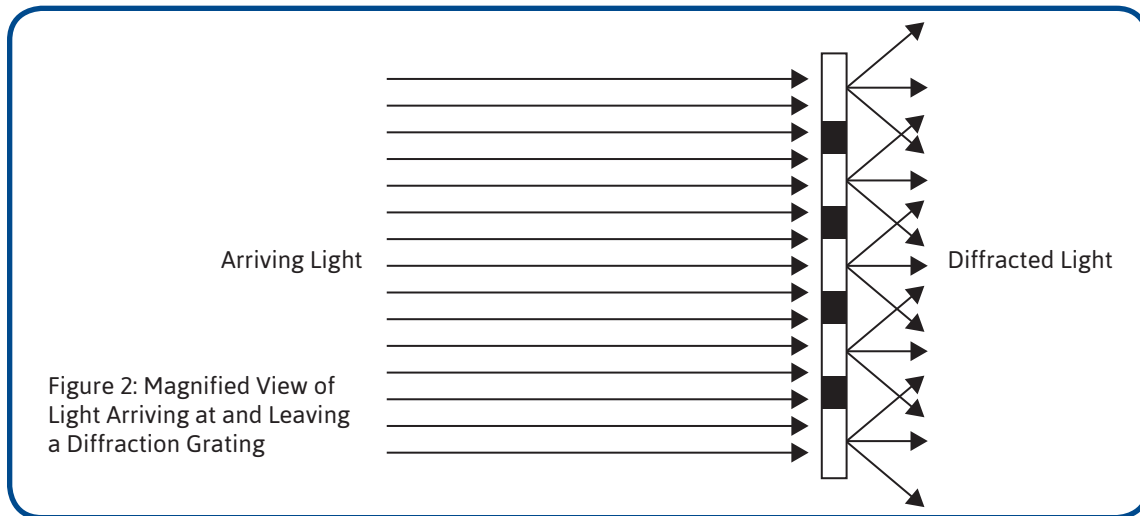

Figure 2: Magnified View of Light Arriving at and Leaving a Diffraction Grating

The diffracted light travels forward and spreads out until it reached a screen. Because the light from each microscopic source on the diffraction grating traveled forward in all directions, each point on the screen is illuminated by light from many, if not all, of the sources on the diffraction grating. Under certain conditions, rays of light can cancel each other out. Imagine an object being pulled on both sides by springs. If the springs pull equally, the object will not move, even though each spring independently would have moved the object. Something like that can happen with light, even though light definitely does not push or pull the screen.

The light coming from the diffraction grating is set up so that except for a few spots, the various colors of light cancel themselves out almost every place on the screen. That is why you get several red spots separated by blankness when you shine a red laser through a diffraction grating. Different colors of light will remain intact at different places on the screen. Thus when you shine white light, which is a combination of many colors of light, you get areas where red light remains (but no other color), areas where green remains (but no other color), and so on. In this way, you can see all the different colors that made up the white light.

## LESSON 11

# Back to the Anchoring Activity

### ACTIVITY 11.1 – REVISITING LEARNING SETS 1–3

Question	Answer	What did we do to find this answer?
How does light travel?		
How do my eyes let me see?		
How do our eyes adjust to darkness?		
Why does the sunlight feel warm?		
Why can I see through some objects but not others?		

Question	Answer	What Did We Do to Find This Answer?
Why can I see my reflection in a mirror but not in wood?		
How do I see color?		
How can white light be separated into the colored lights of which it is composed?		
How can white light be changed into red or almost any other color of light?		

Question	Answer	What Did We Do to Find This Answer?
How can light make a red object look black?		
How can light be mixed to make new colors?		
When are measurement devices useful?		
<b>Supplementary Questions (Not Based Directly on Experiments Done in Class)</b>		
Why is it possible to see an image of a car on a wet road but not on a dry road?		
What is "light speed"?		



## ACTIVITY 11.2 – EXPLAINING HOW WE SEE OBJECTS, INCLUDING OPTICAL ILLUSIONS

### What Will We Do?

We will use what we have learned to explain one part of how we see an optical illusion. Then each group will present their part to represent the whole model.

### Procedure

Each group will present different parts of the explanation for how you see the optical illusion. Your group will choose one of the following ways to present. Then, follow the instructions.

1. Written description

Write a detailed explanation of what happens to light in your part of the phenomenon. Talk about your ideas, and revise your explanation if you need to. Copy neatly, so that you can present it to the class. Your explanation should include evidence from the activities and the experiments you did in Learning Sets 1–3.

2. Musical presentation

Compose any style of song or poem that describes what happens to light in your part of the phenomenon. In your song or poem, remember to be accurate and to explain all the important details and evidence.

3. Consensus model (diagram)

Draw a diagram, based on the consensus model your class has developed, to show what happens to light in your part of the phenomenon. Be prepared to explain your model and the evidence to the class.

4. Physical model

Use any materials you choose to construct a three-dimensional model. Your model should show what happens to light in your part of the phenomenon. Remember the principles you considered when developing models in Lesson 3. Be prepared to explain your model and the evidence to the class.

5. Dramatic performance

Pretend you are light rays and show how light moves from place to place, are scattered or reflected, transmitted, or absorbed in your part of the phenomenon. Prepare a script with different roles for all the group members, so you act with your body and also speak. Remember to include the evidence in your performance.

6. Artistic drawing

Create an artistic drawing that shows what happens to light in your part of the phenomenon. Be sure your drawing is based on the evidence you have learned. Be prepared to explain your drawing to the class.

## Making Sense

People learn best in different ways. By combining all the group presentations, your class will explain how they see the optical illusion in a way that every student will be able to understand. Which presentation helped you understand how you saw the optical illusion best?





## Reading 11.2 – Solar Eclipses

### Getting Ready

If you think a lunar eclipse is an awesome event, a solar eclipse (an eclipse of the sun) is even more awesome. In the middle of the day, the sky slowly becomes dark as the sun disappears, leaving only a halo of light in the sky. A solar eclipse occurs when the moon passes between the sun and Earth so that the sun is all or partly blocked by the moon. Some people consider a solar eclipse to be one of the most amazing events in nature. Many people travel long distances to observe one. The Internet is a good source for photos and videos of solar eclipses.



According to what you learned about phases of the moon, in which phase do you think a solar eclipse can occur? Explain your ideas. If you are not sure, you might want to go back to Reading 10.2 about phases of the moon.



A solar eclipse can only take place when the moon passes between the earth and sun. If the moon's shadow happens to fall somewhere on Earth's surface, from that place people can see some part of the sun being covered or eclipsed by the moon. As you can see in the model, a solar eclipse may be seen from only a small area on Earth. Only people in the region where the moon's shadow falls will be able to see it.

Why does the moon's shadow not cover all of Earth?

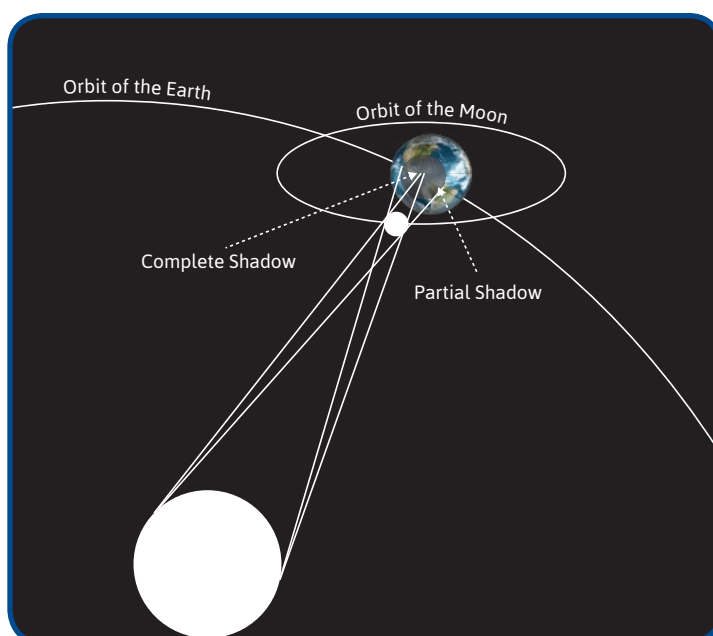
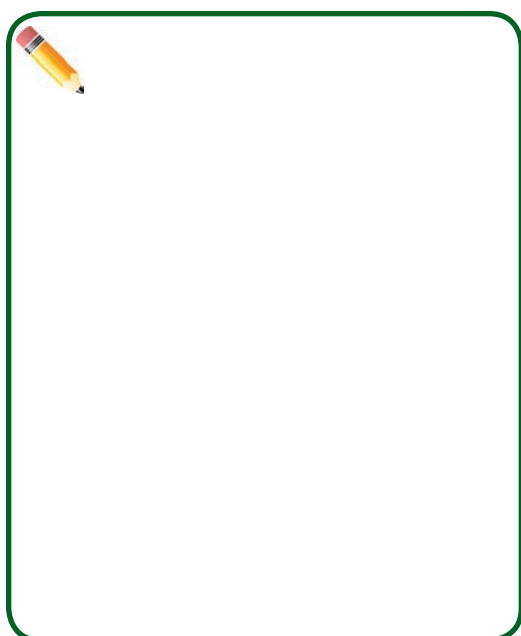

There is evidence that the moon is very slowly getting farther and farther from Earth. Assuming the distance between Earth and the sun does not change, how will this affect the size of the shadow on Earth caused by solar eclipses? Draw a model of a solar eclipse to help you explain your answer. You may want to recall the investigation you did with shadows in Lesson 5.

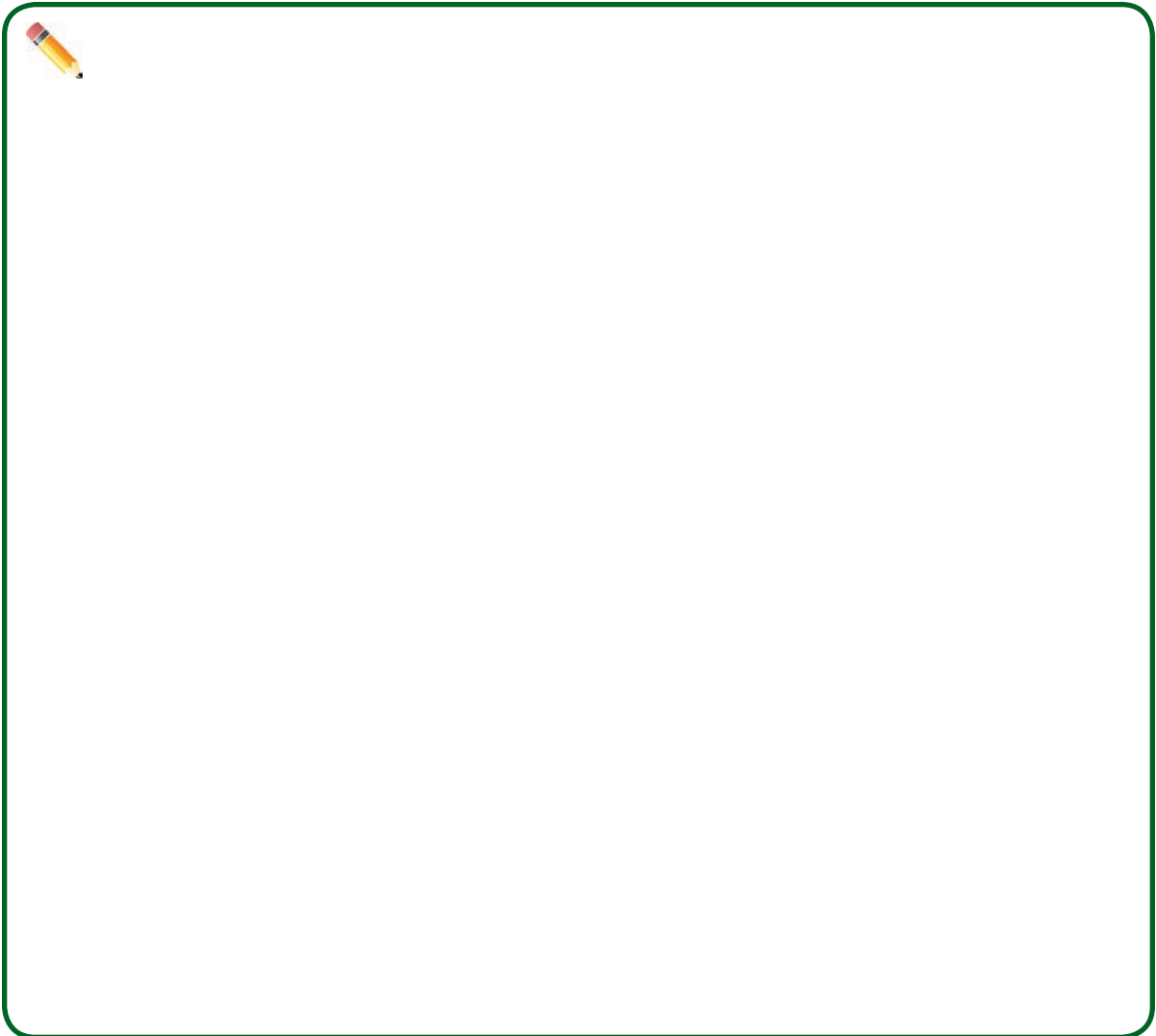

As the obstacle causing the shadow (the moon) moves away from the screen (the earth) and closer to the light source (the sun), the full shadow it makes (the umbra) gets smaller while the partial shadow it makes (the penumbra) gets larger. A solar eclipse may be total or partial, depending on how much of the sun is blocked. Two to five partial solar eclipses occur each year on Earth. A total eclipse occurs only once every eighteen months. Each total eclipse is only visible from a very small area on Earth, where the sun is in the full shadow of the moon. Therefore, it is rare to see a total eclipse at your house or your school. You would have to wait about 375 years to see two total solar eclipses from the same place on Earth.

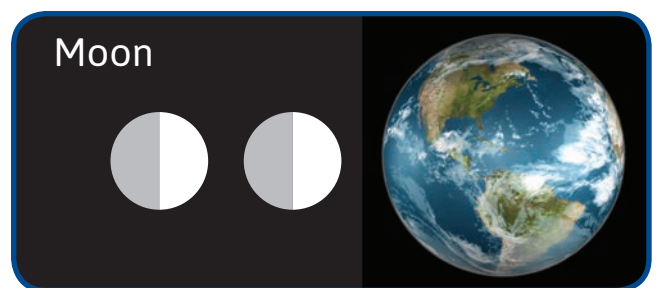

Use the Internet to find out when and where the next total solar eclipse will occur. Use what you learned in the reading about lunar eclipses to explain why there is not a solar eclipse once every month when a new moon phase takes place.



In this photo, you can see a solar eclipse in which the sun appears as a very bright ring surrounding the outline of the moon. Many solar eclipses look like this because sometimes the moon looks too small to block the entire sun. The reason why the moon sometimes appears too small to cover the sun has to do with the moon's orbit around Earth. That orbit is not perfectly round but is shaped like a slight oval. As the moon orbits Earth, its distance from the earth varies. Sometimes the moon is closer to Earth, and sometimes it is a little farther. Therefore, the moon's size seems to vary. When it is farther from Earth, it looks smaller. If an eclipse occurs at that time, it is too small to completely cover the sun, and you can see the bright ring of the sun behind the moon. However, if an eclipse occurs while the moon is closer to Earth, the moon appears large enough to cover the whole sun.



### Summary

Compare a lunar eclipse and solar eclipse by choosing between the different options in the following table.

	Lunar Eclipse	Solar Eclipse
<b>What happens?</b>	The sun/moon gets darker and then reappears.	The sun/moon gets darker and then reappears.
<b>Caused by</b>	The shadow of the sun/earth/moon	The shadow of the sun/earth/moon
<b>Phase of the moon</b>	Full/New moon	Full/New moon
<b>Relative location of the earth, sun, and moon</b>	The sun/earth/moon is between the sun/earth/moon and the sun/earth/moon	The sun/earth/moon is between the sun/earth/moon and the sun/earth/moon
<b>Seen from . . .</b>	All/only a small region on the earth	All/only a small region on the earth
<b>Total or partial</b>	May be only total/only partial/total or partial	May be only total/only partial/total or partial
<b>Frequency</b>	1-2/2-5 a year	1-2/2-5 a year

## LESSON 12

# Infrared Light and the Wave Model

### ACTIVITY 12.1 – WHAT IS LEAVING A REMOTE CONTROL?

#### What Will We Do?

We will explore how a remote control works to explore whether there is light we cannot see.

#### Procedure

Summarize the Demonstration	Predicted Result If the Remote Is Giving Off Light	Actual Result
Turning the TV on and off		
Looking at the remote with a digital camera		
Blocking a remote with a piece of cardboard		
Pointing a remote at a mirror		
Pointing a remote at a transparency		

#### Making Sense

Did your results support the idea that the remote is giving off light? Why or why not?

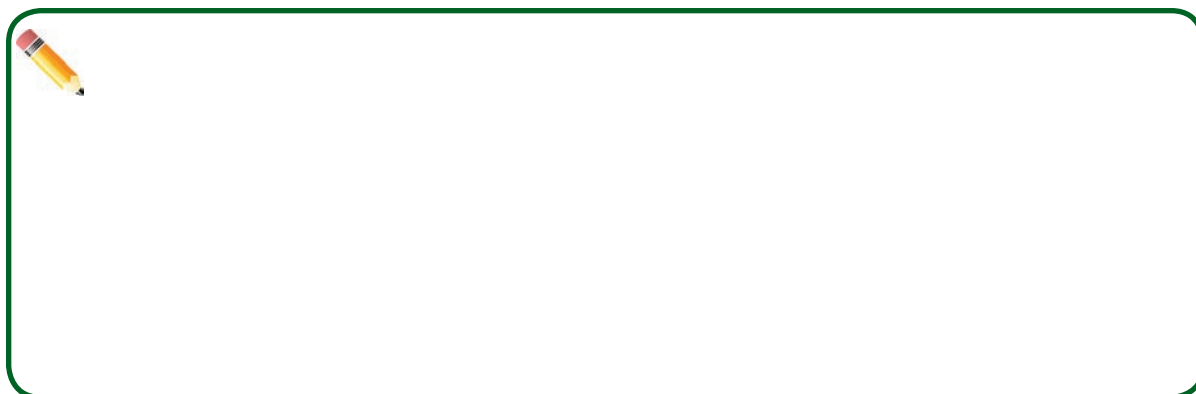



## Reading 12.1 – Infrared Light

### Getting Ready

You do not have to touch a fire to know it is hot. You can see it glowing, and you can feel that it is hot. Have you ever felt something else that was hot even though it was not glowing and you did not touch it? Think of something that fits this description. Describe what the object was and how close you were to be able to feel that it was hot.



As you read, you will learn more about something called infrared light. Infrared (IR) light is why you perceive flames as hot! By the end of this reading, you will be able to name a few ways that people use their understanding of infrared light outside of science class.

### Why Are there Different Colors of Light in a Flame?

A campfire gives off lots of light. When you look at a campfire, most of the flames look yellow. But have you ever noticed that there are different colors in a fire? Look at the photo of a match. The bottom of the flame is blue, the middle is reddish, and the top looks yellow. In class, you learned that the wavelength of light determines what color you see. Light is made of waves, and the distance between any two consecutive waves is called wavelength.



Different wavelengths of light create different responses in your eyes. If a *short* wavelength of visible light reaches your eye, your eye responds by sending a certain signal to your brain. Your brain receives this signal and interprets it as blue. If a *long* wavelength of visible light reaches your eye, your eye responds by sending a different signal to your brain. Your brain interprets this signal as red. If light has an even longer wavelength than red light, it does not create a response in your eye, because your eye is not sensitive to wavelengths that are longer than those of red light.



Because your eye does not respond to this light, it is called nonvisible light. Nonvisible light with a wavelength that is longer than red light is called infrared light. While a campfire gives off different colors of visible light, it gives off nonvisible infrared light, too. Of course, you cannot see it!

### What Makes a Flame Feel Hot?

Even though your eyes cannot detect the infrared light given off by a fire, your skin can. When infrared light reaches your skin, your skin absorbs it. This absorbed light causes the temperature of your skin to increase. Then, nerves in your skin send a signal to your brain that your brain interprets as *hot*. A campfire can feel hot from 10 feet away because it gives off infrared light that your skin detects.

Sometimes objects can give off infrared light without giving off any visible light. A stove in your house may look normal to a camera that detects only visible light, but a camera that detects infrared light can show a different picture. Compare these two photos.

The photo on the left was taken with a regular camera. Your eye cannot tell which burner on the stove is hot because your eye cannot see infrared light. However, if you held your hand near each burner, you could tell which one was hot, because your skin would absorb the infrared light and send a signal to your brain. The photo on the right was taken with an infrared camera. The camera lets your eye see which burner is hot.



With a regular camera, you cannot tell which burner is hot.



An infrared camera shows which burner is hot.

### *How Does This Relate to the Remote Control Activity We Did in Class?*

In class, you used a remote control to send a signal to a television set. Then, you looked at the remote control with a digital camera and saw something flashing that you could not see with your eyes. How did your class determine whether the signal sent by the remote control was light? Explain why the tests your class did helped you decide whether the signal was light.



In class, you determined that the signal sent by a remote control was a kind of light that you cannot see. You now know that this light is called infrared light. The infrared light of a campfire, a match, and a burner on your stove feels hot. Why does it not feel hot when you point a remote control at your skin? A remote control gives off a small amount of infrared light. The amount is so small that it does not heat your skin enough to send a signal to your brain that it feels hot. But it is enough light to be detected by a TV.

### *How Did People Notice Infrared Light in the First Place?*

You used a remote control to study infrared light in class, but the first person to discover infrared light did it long before remote controls were invented. The first person to discover infrared light was Sir Frederick William Herschel. He used a prism to separate sunlight into its colors, just like you did in class with C-Spectra. He knew that light could be absorbed by objects and make them heat up. He wanted to know whether some colors of light heated objects more than others.

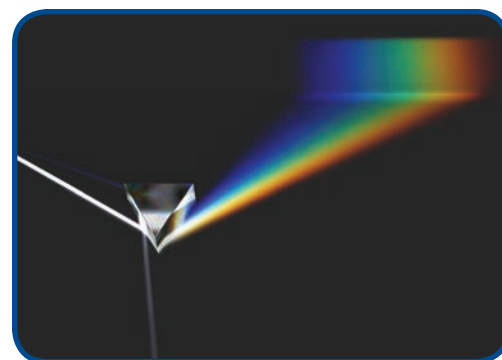

To investigate this, he placed thermometers with blackened bulbs in the different colors of the spectrum and recorded their temperature. Look closely at the following photo of thermometers. The reading on the thermometers increases as you look from blue to red. After noticing this, Herschel placed a thermometer just outside of the red part of the spectrum



where there was no visible light. To his surprise, he found that this area had the highest reading of all! He realized that there must be some kind of light heating up the thermometer but that his eyes could not detect it. This light was infrared light.

Using what you know about colors and light absorption, explain why Sir Frederick William Herschel used thermometers with blackened bulbs in his experiment.

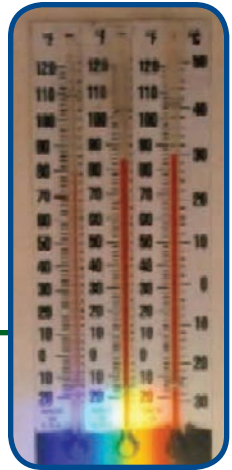
A green-bordered box containing a pencil icon, intended for a student's answer.

### *How Do People Use Infrared Light?*

Even though you cannot see it, infrared light is very important. Since Herschel discovered that sunlight contains infrared light, astronomers have been using special IR cameras to look at stars and other objects in the sky. Just as a hot stove looks different to a regular camera than to an infrared camera, objects in the sky look different, too. This picture shows a galaxy photographed with a regular camera (left) and with an infrared camera (right). The infrared camera shows parts of the galaxy that are invisible to the eye because they do not give off visible light.



Some infrared goggles work by detecting the infrared light that objects give off. Other IR goggles use an infrared flashlight to bounce infrared light off of objects. Using an infrared flashlight makes objects appear brighter to someone wearing IR goggles. If someone wearing IR goggles were to shine an infrared flashlight at you, what would you see? Why?

A green-bordered box containing a pencil icon, intended for a student's answer.

### *How Do Doctors Use Infrared Light?*

Doctors also use infrared light to check the amount of oxygen in a patient's blood. Doctors discovered that oxygen-rich blood absorbs the most infrared light, and it transmits or scatters visible red light. That probably makes sense to you because it explains why your blood appears red! If blood is not oxygen-rich, it transmits more infrared light and less visible red light. By shining red and infrared light through a patient's finger and measuring the amount of each type of light that comes out the other side, doctors can determine how much oxygen is in the blood. Knowing how blood absorbs, transmits, or scatters light allows doctors to test blood without having to take a blood sample from people.



Suppose you were wearing a sensor on your finger, and it detected a lot of infrared light and not much visible red light. Does this mean that your blood has a lot of oxygen in it, or only a little oxygen? Why?



In this reading, you have learned how infrared light was discovered and you have learned about many uses for infrared light. But infrared light is not the only kind of light you cannot see. In the next lesson, you will learn about other types of light that you cannot see and how nonvisible light affects your life every day.



## Homework 12.1 – Is the Remote Emitting Light?

### *Purpose*

These questions will help you make sense of the remote control activity you did in class.

In class, you used the remote control to compare infrared light and visible light. First, choose the demonstration that you understand best from the following list, and then answer the questions that follow:

- turning the TV on and off
  - looking at a remote with a digital camera
  - blocking a remote with a piece of cardboard
  - reflecting a remote off a mirror
  - shining a remote through a transparency
- a. How did this investigation help you figure out whether the remote was emitting light or not?

- b. Explain why you got a similar result using a remote and using a flashlight. (Hint: You may want to remember the earlier lesson where you used visible light instead of IR.)
- c. To use your understanding even more, explain to someone at home how a remote control works.
- d. Is any of the light from the remote absorbed? Design an investigation you could do to figure out the answer to this question. Describe or draw (or both) how you would test whether any IR light is absorbed. (Hint: Look back to Lesson 8 to remind yourself of how you determined that light could be absorbed.)
- e. Make a prediction. If the remote were giving off light and you did the demonstration you described, what would you expect to happen? Why?

## ACTIVITY 12.2 – INTRODUCING THE WAVE MODEL

### What Will We Do?

We will do some activities to learn more about the differences between visible and nonvisible light. Then we will revise our model of light to account for new evidence.

### Procedure

1. As your teacher changes the pitch coming from the computer, raise your hand when you can no longer hear the sound.
  - a. Did everyone's hand go up at the same time? Why?
  - b. Are there sounds that you cannot hear? Explain.
2. Describe the wave model presented in class.
3. Based on your understanding of the wave model, explain why your eye could not detect the light coming from the remote but the camera could.

## Making Sense

1. According to the wave model of light, what makes blue light different from green light?
2. Compare red light with the infrared light that comes from the remote. (Remember that *compare* means to describe what is similar and what is different.)
3. Describe how visible light is different from nonvisible light.



## LESSON 13

# Ultraviolet Light and Nonvisible Light Imagery

### ACTIVITY 13.1 – INVESTIGATING UV LIGHT

#### What Will We Do?

We will investigate another type of light that our eyes cannot detect: ultraviolet light.

#### Data

1. Sunscreens are designed to protect your skin from UV light. Predict what you will get in the experiment, then make measurements and compare the results with your predictions.

	Ultraviolet (UV) Light	Visible Light
Reading without sunscreen		
Your prediction of the percent of light blocked by the sunscreen		
Actual reading with sunscreen		
Actual percent of light blocked by sunscreen		



2. Is the percent of UV light blocked by the sunscreen greater or less than the percent of visible light blocked? Is this similar to what you predicted?
  
3. Why would companies want their sunscreen to absorb nearly all of the UV light that hits it but none of the visible light?
  
4. What would sunscreen look like if it absorbed all of the visible light that hit it?

### **Making Sense**

How does the sunscreen work similar to the color *filters* that you have used in previous lessons?





## Homework 13.1 – UV Light and UV/IR Imagery

### Purpose

You probably know someone who wears glasses to help them see better. This homework asks you to think about an imaginary company that has invented some special glasses. As you do this homework, you will apply what you have learned about ultraviolet and infrared light.

A company that makes eyeglasses claims to have developed a special coating for the lenses. They say that the coating will block 100% of the UV and 50% of the IR light that hits the lenses. The following graphs show data for the visible, UV, and IR light transmitted by eyeglasses with and without the coating.

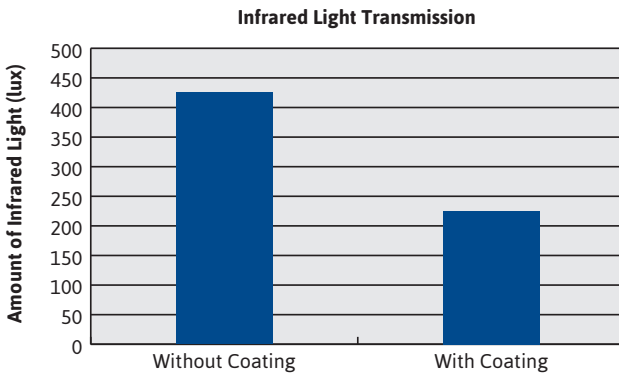
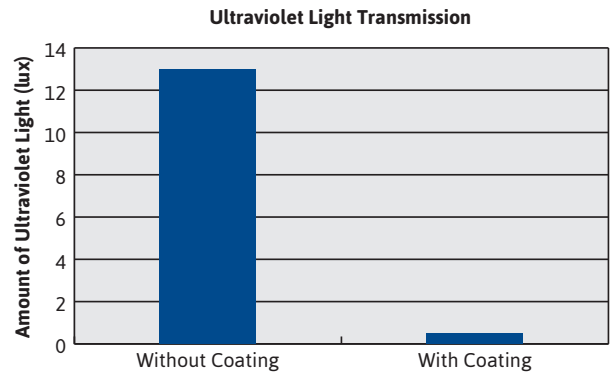
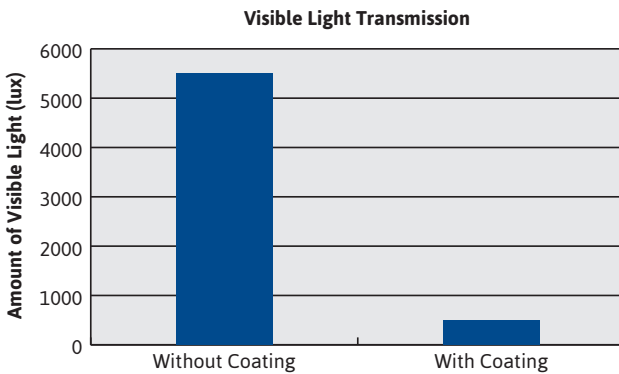





## Reading 13.1 – Nonvisible Light

### Getting Ready

Imagine that your remote control used visible instead of nonvisible light. Would this be a good idea? Why?



Today, you will read more about nonvisible light. You probably do not realize it, but nonvisible light plays an important role in your life every single day! By the end of this reading, you should be able to describe how radios, cell phones, microwave ovens, or x-rays machines use nonvisible light. By explaining even one of those to someone who is not in your class, you can help them understand something interesting. And you will help yourself understand nonvisible light even better by explaining it to someone else!

### How Does Light Travel?

In class, you learned that light travels in a similar way to waves moving across water. You saw that when water waves move in a pan of water, the ripples can be spaced very close together (having a small wavelength) or very far apart (having a large wavelength).



Light can also travel with a wavelength that is very small or very large. But your eyes can only detect light if its wavelength is within a certain range. Human eyes can only detect light with a wavelength between 400 and 700 nanometers. A nanometer is one billion times smaller than a meter. How small is that? A single hair on your head is about 80,000 nanometers wide. This means that the wavelength of visible light is more than a hundred times smaller than the width of your hair! Try to think about this before you keep reading. You may need to read through this description again to really understand how small the range of light is that your eye can see. It is amazing!

### How Much Nonvisible Light Is There?

Infrared light has a wavelength that is a little greater than 700 nanometers. Therefore, you cannot see it. Ultraviolet light has a wavelength that is a little less than 400 nanometers.

Wavelength < 400 nanometers = nonvisible (UV)

Wavelength between 400–700 nanometers = visible

Wavelength > 700 nanometers = nonvisible (IR)

Even though the wavelengths of infrared and ultraviolet light can be close to the wavelengths that your eyes can detect, your eyes still cannot detect them.

Nonvisible light can have a wavelength millions of times smaller than a human hair or bigger than the entire Earth! Because nonvisible light can have so many different wavelengths,

scientists created a system to keep track of them. In this system, scientists have divided all of the possible wavelengths into categories. You have probably heard of some of the categories, because many of the devices you use every day operate using nonvisible light.

The longest wavelengths of light are called *radio waves*. Find them on the following chart. The shortest wavelengths are called *gamma waves*. Find them on the chart. In between are microwaves, x-rays, infrared light, ultraviolet light, and visible light.

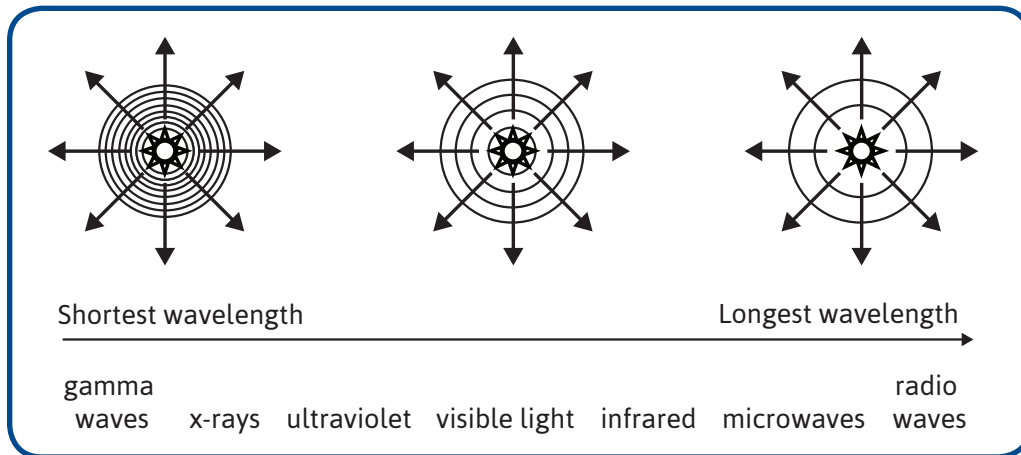

There is a lot of light in the world. Some of it is visible. Some of it is nonvisible. Do you think that most of the light that hits your eye is light that you can see or not? Explain your answer. (The previous chart should help you.)



Although you cannot see nonvisible light, your body can detect it in other ways. Infrared light makes you feel warm. When you go out into the sunlight, your skin absorbs infrared light. You cannot see that light, but you can feel it as warmth. Your skin also absorbs visible light and ultraviolet light when you are in the sun. In class, you learned that the ultraviolet light from the sun can give you sunburn. Even though you cannot see it, nonvisible light from the sun is very important for making Earth a warm, comfortable place to live.

### *Some Ways We Use Nonvisible Light*

Many of the devices that you use every day rely on light that your eyes cannot detect. Do you ever listen to a radio? Radios are designed to detect radio waves. Radio waves are a type of nonvisible wave given off by an antenna at a radio station. Just like your eye detects light and sends a signal to your brain, a radio antenna detects radio waves and sends a signal to your speakers. The radio speakers then produce a sound that you can hear.

Radio waves have the longest wavelength of any kind of light. Their wavelength can be many kilometers long.



Even before reading today, you probably know something about microwaves. A microwave oven uses microwave light waves. Look back at the chart of types of light to see how microwave light compares to other types.

Years ago, scientists discovered that water easily absorbs microwave light. When microwaves are absorbed by water, the temperature of the water increases. This is useful to know because nearly all of the food you eat has some water in it. When you put your food in a microwave oven, the water in that food absorbs nonvisible microwave light and heats up. The heated water then heats the food around it, which makes your food hot.

Look at this photo. When someone takes food out of the microwave oven, the food is hot but the container the food is in may still be quite cool. Why do you think a microwave oven can heat food without heating the bowl?



Microwaves are also useful for sending signals. Here is something you probably did not know: When you talk on a cell phone, your phone is actually sending and receiving microwaves!



### *Using X-rays to See through Things*

While long wavelengths of light are useful for sending signals over large distances, shorter wavelengths of light are useful for other purposes. X-rays and gamma rays make it possible for people to see through things. Have you ever broken a bone? If so, a doctor probably used an x-ray machine to take a picture of your bones.

Using an x-ray light source, doctors send x-rays through your body toward special photographic film on the other side. When x-rays strike the film, they are absorbed and turn the film black. Bones show up white on an x-ray because these are the areas of the film where very few x-rays are absorbed by the film.

If a person wears a metal ring while they have an x-ray, the ring will appear bright white. The photo on the right shows this. Now that you understand more about light, absorption, and transmission, you can probably explain this. Does metal mostly *transmit* or *absorb* x-rays? Explain your answer.



### *X-rays at the Airport*

X-rays are useful for airport security workers, who check passengers' luggage for dangerous materials. By using x-rays, they can look inside luggage without opening it. When you fly on a plane, workers shine x-rays on your luggage. The picture to the right shows what they see. You may notice that the objects in this picture show up as different colors. An airport x-ray machine works a little differently than a doctor's x-ray machine. The objects do not look like bones, do they?



All x-rays have a wavelength of about a single nanometer, but they can be a little bigger or smaller. A medical x-ray machine only uses one wavelength of x-rays, but an airport machine uses many different wavelengths. Since different materials absorb different wavelengths of x-rays, workers can tell what kinds of materials are inside of bags. This helps them to know whether something is made of metal, rubber, or cloth. Is that not amazing? They never even have to open your bag to know what is inside!

However, x-rays can be damaging if a person is exposed to them too often. Medical people wear metal aprons made of lead, or they stand behind a lead wall when they take x-rays. Why would a dark-colored cloth not work as well as lead?

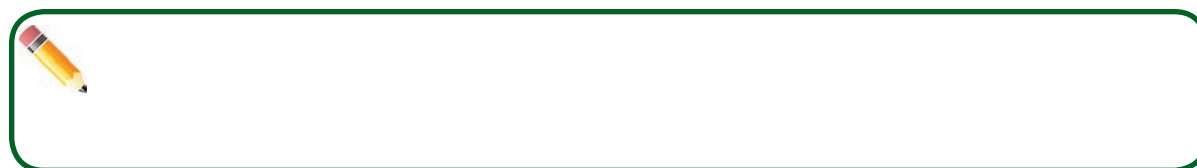

In this unit, you have learned a lot about light. You learned that light must enter your eye in order for you to see. You learned that there are many wavelengths of light that your eye cannot detect. Even though you cannot see it, you use nonvisible light every day. It makes you warm, helps you communicate, heats your food, and can even help you see through things!

## ACTIVITY 13.2 – HOW WOULD THE WORLD LOOK IF PEOPLE COULD SEE UV AND IR LIGHT?

### What Will We Do?

We will see how the world might look if our eyes could detect nonvisible ultraviolet or infrared light.

### Making Sense

1. Images taken with IR and UV cameras sometimes appear colorful. How do you know that the color in these pictures must have been added artificially?
2. Based on the pictures you have seen in class, why might UV and IR imagery be useful for astronomers?
3. Why might UV and IR imagery be useful for firefighters?
4. During a power outage, the lights in a city can all go out. If you had a choice of using either a UV or IR camera to help you see, which one would you choose? Explain your choice.





## Homework 13.2 – UV Light and UV/IR Imagery

These questions will help you think about ultraviolet and infrared light in some ways you did not study in class. Applying what you have learned to new situations helps you understand concepts better.

Start by looking carefully at this photo.

1. The image was taken with an IR camera. It shows a car. Is the car running, or was it recently driven? How can you tell?

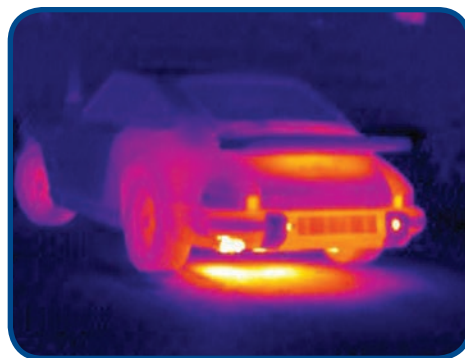

Here is another way of thinking about UV light. The ozone layer protects living things on Earth because (a) it absorbs harmful UV light and (b) it transmits visible light. Scientists who study the ozone layer use a satellite to take pictures of the Earth. The pictures show the amount of UV light from the sun that bounces off of the Earth's surface and its atmosphere.

2. If the satellite measures a lot of UV light reflected by one place on Earth, why is that evidence that there is not much ozone in that location? Use what you have learned about *reflection* and *absorption* in your response.

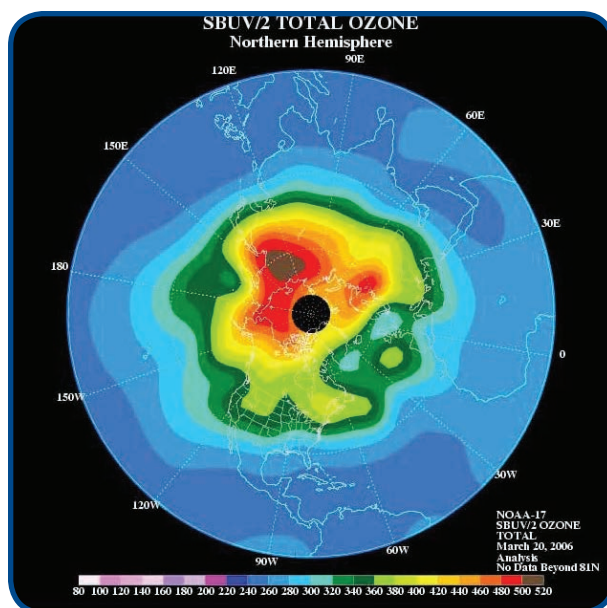

Some scientists are concerned that human activities have created a hole in the ozone layer. A hole means that the earth is not as well protected against harmful UV rays. If you are interested, you could learn more about this topic on the Internet.













Student Edition

# Physical Science

Can I Believe My Eyes?

*Investigating and Questioning our World  
through Science and Technology (IQWST)*

*Developed with funding from  
the National Science Foundation*



PS1 Eyes SE 2.0.1

ISBN-13: 978-1-937846-47-3